



FAST SLIDING GATES

Fast electromechanical automation
for sliding gates

ELDOCE



Be ahead



ARES VELOCE SMART BT A500



A fast 24 V gate operator (up to a speed of 25 m/min) which is suitable for very intensive use on sliding gates up to 500 kg. It is equipped with D-Track torque management system and the control panel is U-Link compatible. It features an electromagnetic limit switch for greater reliability and longevity. The Ares Veloce is ideal for sites which require fast operating speeds, reduced waiting times and high levels of security.

ARES VELOCE SMART BT A500 | |

	Code	Name	Description
	P926198 00002	ARES VELOCE SMART BT A 500	24 V operator for sliding gates weighing up to 500 kg. Speed without load 25 m/min. U-Link compatible and equipped with an electromagnetic limit switch.

Benefits of ARES VELOCE SMART BT A500



Speed: The fast opening of the ARES SMART BT A500 reduces waiting times and allowing quicker access, reducing the risk of an accident.



security

Security: The fast operating speed means that the ARES VELOCE SMART BT A500 closes quickly, reducing the risk of entry by unauthorised people.



U-Link: The ARES VELOCE SMART BT A500 operator is compatible with the U-Link communication protocol, through the integrated MERAK SV 24 V control panel.



d-track

D-Track: An intelligent torque management system which updates the level of torque required to perform the operation, allowing it work at the optimum level regardless of weather conditions, temperature or the degree of wear and tear on the device.



Personalised key: the lever release makes it easy to release the motor and the personalised key is unique, providing increased security.



Screws on the front: By putting the fastening screws on the front of the casing, installation and maintenance are easier and more convenient, even in confined spaces.

MERAK SV



- Integrated control panel for the ARES VELOCE SMART BT A500 24 V operator. Main features: removable colour coded terminal blocks, digital display for programming scenarios, integrated two-channel receiver, slowdown during opening and closing. Main functions: automatic closing, fast closing, pedestrian opening, hold-to-run operation, maintenance notification.

	ARES BT A500
Control unit	MERAK SV
Panel power supply	230 V
Motor voltage	24 V
Power consumption	400 W
Pinion module	4 mm (25 teeth)
Speed without load	25 m/min
max. weight	500 kg
max. torque	20 Nm
Impact reaction	8K2 safety edge (not supplied)
Locking	Mechanical
Manual operation	Mechanical release with lever
Type of use	Intensive
Protection rating	IP24
Environmental conditions	-20 - 55°C

Dimensions

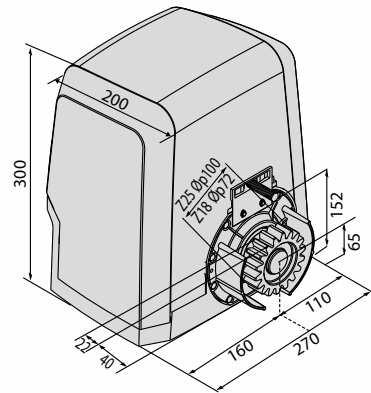

To ensure the highest safety standards in accordance with standard EN12453, it is necessary to fit the 8K2 safety edge (not supplied. Refer to the operator manual for the 8K2 edge models to use).





RECOMMENDED ACCESSORIES

	D571054 - CFZ Galvanized steel rack, module 4, 22 x 22 mm cross-section, length 2 m, fastened by welding. Maximum load 2,000 kg.
	P125018 - THEKE B PRA 01 Metal protective casing for sliding operators, ARES and ICARO series
	P125035 - SL BAT2 Emergency battery kit
	N999156 - SFI Mounting plate for ARES and ICARO (supplied with the operator)
	P111468 - B EBA RS 485 LINK Expansion card for connection of groups of units with serial command management
	D114093 00003 - RADIUS LED BT A R1 Flashing with LED technology and built-in receiver antenna. 24V power supply
	D114168 00003 - RADIUS LED BT A R1 W Flashing with LED technology, built-in receiver antenna and smoky grey cover. 24V power supply.
	P111528 - THEA A15 O.PF Pair of adjustable photocells with built-in flashing light. Possibility to direct the beam 40° horizontally and 10° vertically. Synchronised infrared signal to avoid any possibility of blinding. 30 m range. 24 V ac/dc power supply. For external application.
	P111782 - COMPACTA Set of photocells adjustable 180° horizontally 20 metre range. 12-33Vac / 15-35Vdc power supply.
	D111904 - MITTO B RCB02 R1 2-Channel transmitter. 50/100 m range. 12 V power supply with 1 type 23 A battery
	D111906 - MITTO B RCB04 R1 4-Channel transmitter. 50/100 m range. 12 V power supply with 1 type 23 A battery



ICARO VELOCE SMART AC A1000

-  d-track
-  ee link
-  er ready
-  U-Link
-  Oil Gear

Empowered by
U-LINK



A fast 230 V gate operator (up to a speed of 25 m/min) which is suitable for very intensive use on sliding gates up to 1,000 kg. This is extremely robust operator features an oil bath gearbox for higher performance. It is equipped with the exclusive D-Track torque management system and absolute encoder for precision movement. It features an electromagnetic limit switch for greater reliability and longevity. The control panel is U-Link compatible and is tamper-resistant. The Icaro Veloce is the ideal for sites which require fast operating speeds, reduced waiting times and high levels of security.

ICARO VELOCE SMART AC A1000 | |

	Code	Name	Description
	P925256 00002	ICARO VELOCE SMART AC A 1000	230 V operator for sliding gates weighing up to 1,000 kg with absolute encoder. Gate panel speed 25 m/min. Electromechanical limit switch. With mechanical safety clutch, manages torque using D-Track technology and features oil bath gearbox. Control panel is U-Link compatible and tamper-resistant.

Benefits of ICARO VELOCE SMART AC A1000



Speed: The fast opening of the ICARO VELOCE SMART AC A1000 reduces waiting times, allowing quicker access, particularly useful for commercial and industrial sites.



security

Security: The fast operating speed means that the ICARO VELOCE SMART AC A1000 closes quickly, reducing the risk of entry by unauthorised people.



U-LINK

U-Link: The ICARO VELOCE SMART AC A 1000 operator is compatible with the U-Link communication protocol, through the integrated LEO B CBB control panel.



d-track

D-Track: An intelligent torque management system which updates the level of torque required to perform the operation, allowing it work at the optimum level regardless of weather conditions, temperature or the degree of wear and tear on the device.



Oil Gear

Oil Gear: Oil bath gearbox unit. The component gears of the transmission are immersed in an oil bath to ensure perfect lubrication throughout their service life.



Technopolymers: The combined use of metal and plastic-technopolymer gears provides the perfect engagement between the surfaces, allowing for reduced friction and the highest levels of reliability in intensive use.



Personalised key: the lever release makes it easy to release the motor and the personalised key is unique, providing increased security.

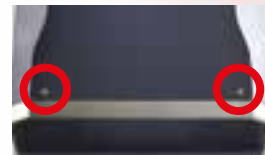

Screws on the front: By putting the fastening screws on the front of the casing, installation and maintenance are easier and more convenient, even in confined spaces.

LEO B CBB L02



- Specific integrated control panel for the ICARO VELOCE SMART AC A1000, 230 V operator. Main features: removable colour coded terminal blocks, digital display for programming scenarios, integrated two-channel receiver, torque control with D-Track technology, slowdown during opening and closing. Main functions: automatic closing, fast closing, pedestrian opening.





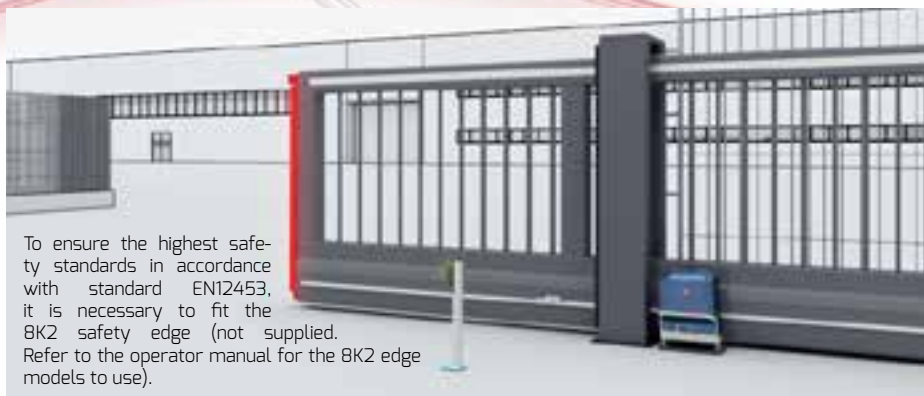
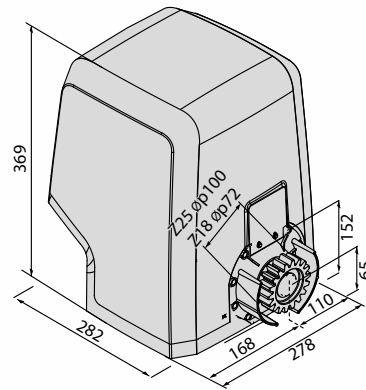



	ICARO VELOCE SMART AC A1000
Control unit	LEO B CBB L02
Panel power supply	230 V
Motor voltage	230 V
Power consumption	750 W
Pinion module	4 mm (25 teeth)
Speed without load	25 m/min
max. weight	1,000 kg
max. torque	40 Nm
Impact reaction	BK2 safety edge (not supplied)
Locking	Mechanical
Manual operation	Mechanical release with lever
Type of use	Very intensive
Protection rating	IP24
Environmental conditions	-15 - +55°C

Dimensions



To ensure the highest safety standards in accordance with standard EN12453, it is necessary to fit the BK2 safety edge (not supplied). Refer to the operator manual for the BK2 edge models to use).

RECOMMENDED ACCESSORIES

	D571054 - CFZ Galvanized steel rack, module 4, 22 x 22 mm cross-section, length 2 m, fastened by welding. Maximum load 2,000 kg.
	P125018 - THEKE B PRA 01 Metal protective casing for sliding operators, ARES and ICARO series
	N999156 - SFI Mounting plate for ARES and ICARO (supplied with the operator)
	P111468 - B EBA RS 485 LINK Expansion card for connection of groups of units with serial command management
	D114093 00002 - RADIUS LED AC A R1 Flashing with LED technology and built-in receiver antenna. 230V power supply.
	P111528 - THEA A15 O.PF Pair of adjustable photocells with built-in flashing light. Possibility to direct the beam 40° horizontally and 10° vertically. Synchronised infrared signal to avoid any possibility of blinding. 30 m range. 24 V ac/dc power supply. For external application.
	P111782 - COMPACTA Set of photocells adjustable 180° horizontally 20 metre range. 12-33Vac / 15-35Vdc power supply.
	D111904 - MITTO B RCB02 R1 2-Channel transmitter. 50/100 m range. 12 V power supply with 1 type 23 A battery
	D111906 - MITTO B RCB04 R1 4-Channel transmitter. 50/100 m range. 12 V power supply with 1 type 23 A battery

What is U-Link?

The technology that gives you more power

U-Link, Universal Link, is an exclusive BFT platform that can be used to create high-tech ecosystems.

In Home Access Automation, it can be used to communicate with all home access automation devices of any brand.

This saves you time and allows you to control everything easily and worry-free.

It is intuitive

Easy to install and to use

It is scalable

You can add as many devices as you want

It is flexible

It allows you to create groups of interconnected products

It is practical

Works with or without an internet connection

It is functional

It can be configured remotely using dedicated applications

Everything on one screen: find out more about this amazing technology

A world-exclusive platform that **can be used to create high-tech ecosystems** offering a vast range of solutions for many different sectors.

This proprietary platform which is a key feature of BFT products, thanks to the B-EBA cards and the Clonix U-Link receiver, is suitable for any protocol or product for access automation (including BFT products, non-BFT ones and older versions) and it can be used in a variety of different sectors. This means any device becomes a smart device which can be interconnected with other systems, using a language that is becoming universal.



U-Control HOME

U-Control HOME is the application that allows you to open the gate to your home and to remotely control BFT automations using your own smartphone. The iOS version can be used to automatically open the entrance system when you are close to it.



U-Base 2

A software package used for easily and conveniently installing, performing maintenance and identifying any faults in the U-Link compatible operators, easily and conveniently.



U-SDK

U-SDK is the application which allows BFT automations to be made compatible and easily integrated with a BMS network.

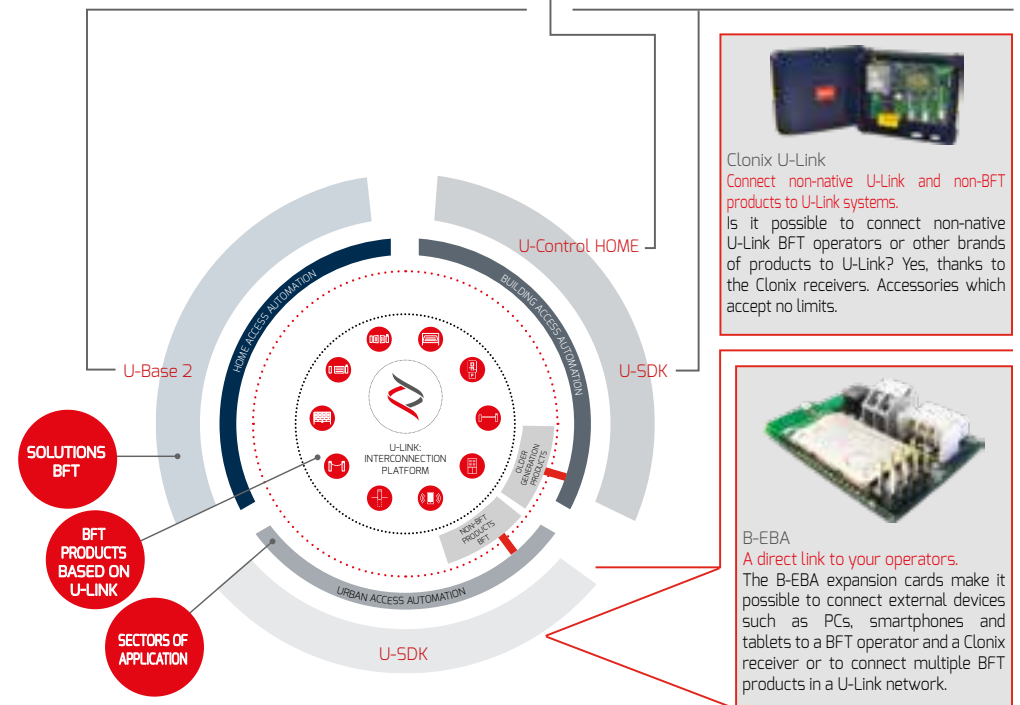

Clonix U-Link
Connect non-native U-Link and non-BFT products to U-Link systems.
Is it possible to connect non-native U-Link BFT operators or other brands of products to U-Link? Yes, thanks to the Clonix receivers. Accessories which accept no limits.

B-EBA
A direct link to your operators.
The B-EBA expansion cards make it possible to connect external devices such as PCs, smartphones and tablets to a BFT operator and a Clonix receiver or to connect multiple BFT products in a U-Link network.

The contents of this catalogue (images, technical descriptions, illustrations) are the sole property of BFT SpA. Its reproduction, in any form or format, is strictly forbidden. All rights reserved, copyright 2016. The information contained in this publication is to be considered indicative. BFT reserves the right to make changes without giving any prior notice. Cover Designed by Freepik



Bft SpA

Via Lago di Vico, 44 - 36015 Schio (Vicenza), Italy
Dedicated Direct Telephone Number 06 96 706 706
for professionals working in the sector.

www.bft-automation.com



Be ahead