

# SP3500

## RANGE

Electromechanical automation for rack sliding gates

P925207 00002

## SMART TECHNOLOGY

Hydrodynamic gear for smooth gate starts and stops.

## SAFE USE

- The strength and compactness of the structure guarantee the maximum reliability of operation over time.
- The operator makes it possible to automate any type of gate, even the heaviest. Up to 7,000lbs and 100 Feet

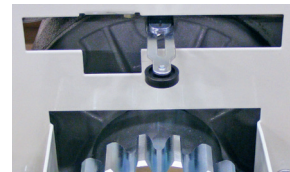

## TECHNICAL FEATURES

Control panel	SIRIO TEL (incorporated)
Reversible/irreversible operator	irreversible
Power supply	230 V~ ± 10%, 50 Hz three-phase
Absorbed power	2 hp (1500 W)
Thermal protection	overload cutout inside the control panel
Leaf speed	34'.5"/min
Output revolutions	30 min
Pinion pitch	6 (18 teeth)
Type of limit switches	electromechanical
Manual release	mechanical release with knob
Operating cycle	very intensive use
Environmental conditions	from 5°F (-15°C) to 122°F (+50°C)
Degree of protection	IP 24
Operator weight	119 lbs (~54 kg)
Dimensions	see drawing
Brake	Electric

- T: US. 1877 995 8155
- [info.bft@bft-usa.com](mailto:info.bft@bft-usa.com)
- [www.bft-usa.com](http://www.bft-usa.com)



tuned to you

**BFT Americas, Inc.**

6100 Broken Sound Parkway N.W.,  
Suite 14  
Boca Raton, FL, 33487

# SP3500

## DIMENSIONS

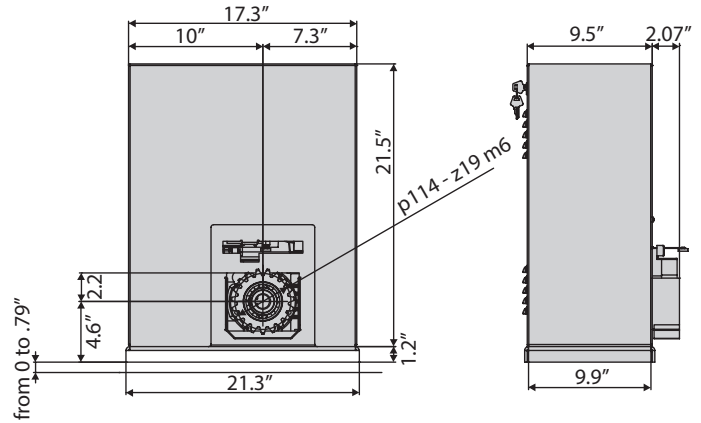

## ACCESSORIES

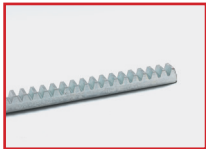

**D571491 - CFZ6**  
30x30 6-pitch rack.  
2 m lengths.  
Priced per meter

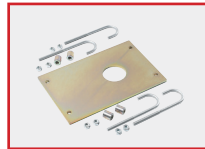

**P125015 - BASP**  
Adjustable anchoring  
base.

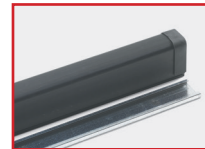

**N190039 - CSP 10**  
Shock absorber profile,  
length 39".

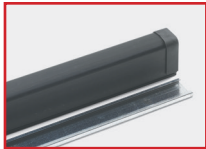

**N190040 - CSP 20**  
Shock absorber profile,  
length 78.74".

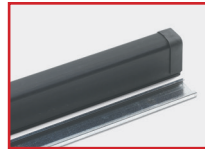

**N190041 - CSP 25**  
Shock absorber profile,  
length 98.42".

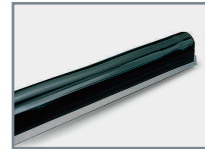

**N190105 - BAR C**  
Rubber safety edge with  
double profile.

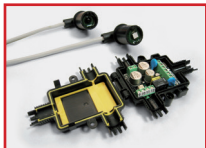

**P111401 00001 -  
VENTIMIGLIA NS**  
Infrared obstacle  
detection device for BIR  
C safety edge compliant  
with standard EN 12978.

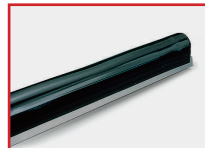

**N190104 - BIR C**  
Rubber safety edge and  
brackets.

- T: US. 1877 995 8155
- [info.bft@bft-usa.com](mailto:info.bft@bft-usa.com)
- [www.bft-usa.com](http://www.bft-usa.com)



tuned to you

**BFT Americas, Inc.**  
6100 Broken Sound Parkway N.W.,  
Suite 14  
Boca Raton, FL, 33487