

PHOBOS BT L

RANGE

Electromechanical operator
for swing gates up to 16' and 550 Lbs



PHOBOS SERIES

KLEBR935245 01 Single Phobos Kit and 12x14 enclosure with battery backup
KLEBR935245 02 Dual Phobos Kit and 12x14 enclosure with battery backup
R935245 00001 Single Phobos Kit
R935245 00002 Dual Phobos Kit

SMART TECHNOLOGY

Control unit compatible with the EELink protocol.



12 x 14 LEB enclosure with battery backup

SAFE USE

- This version powered at 24V has been specially designed for simpler and faster installation in compliance with latest safety standards.
- Thanks to the obstruction sensing device, the operator reverses motion and prevents damage to people and vehicles in the event of contact.



TECHNICAL FEATURES

Control panel	LIBRA UL R
Reversible/irreversible operator	irreversible
Power supply	120 V, 60 Hz single-phase
Absorbed power	0.05 hp (40 W)
Thermal protection	integrated in the control unit
Rod working stroke	16.1" (410 mm)
Rod speed	0.78"/sec (20 mm/s)
Opening or closing time	20 s
Impact reaction	torque limiter integrated in the control panel
Lock	mechanical on opening/closing
Limit switches	magnetic
Manual release	release key
Operating cycle	intensive use
Environmental conditions	from -4°F (-20°C) to 140°F (+ 60°C)
Degree of protection	IP44
Operator weight	14.3 lbs (~6,5 kg)
Dimensions	see drawing next page

- T: US. 1877 995 8155
- info.bft@bft-usa.com
- www.bft-usa.com



tuned to you

BFT Americas, Inc.

6100 Broken Sound Parkway N.W.,
Suite 14
Boca Raton, FL, 33487

PHOBOS BT L

DIMENSIONS

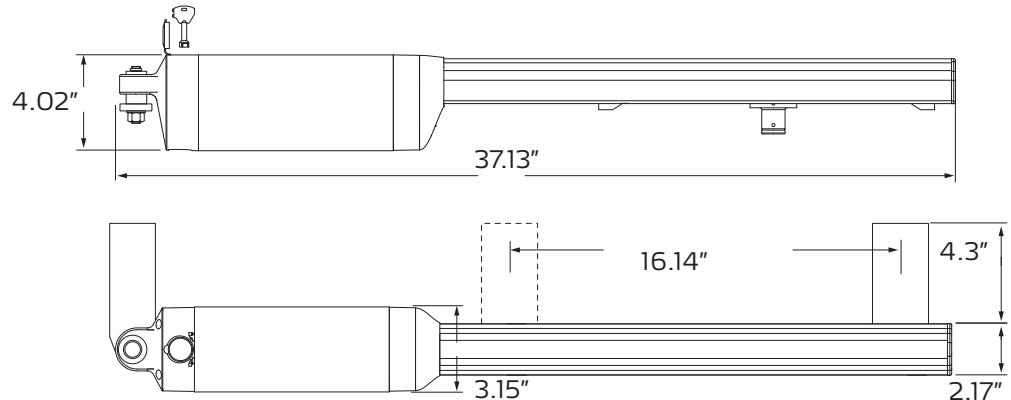

ACCESSORIES



D113701 00001 - LIBRA UL R

• Universal control panel for one or two 24V motors with 1 wire limit switch for each motor. • Quick wiring through plug-in terminal strips. • LCD display for quick programming and easy fault diagnosis. • Crushing prevention by electronic torque self-adjustment. • Built-in 63 remotes rolling code receiver. • Optional serial control management, solenoid electric lock and battery backup.



KELIBRC012U - LIBRA 12 X 14 PRE-WIRED ENCLOSURE

12 x 14 enclosure box with Libra UL/CSA and 2 -9Amp/h batteries for back-up poweroutlet On/Off switch



P125005 - BT BAT
24 V dc battery backup system for PHOBOS BT, PHOBOS BT L, IGEA BT it includes a charger board that activates the batteries when power is off and charges the batteries when power is on.



P111323 - SCS

Serial connection interface for LIBRA UL R.



D111761 - ME BT

12/24 Vac electric lock interface for ECB locks with BT operators.



D121017 - ECB SX

Left-hand horizontal electric lock. Also available in right-hand and vertical versions.



D610180 - CLS/52

Release key for LUX, PHOBOS BT, PHOBOS BT L and DEIMOS BT.

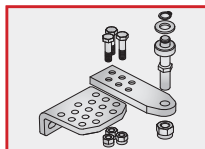

I099838 - ARB PP

Adjustable post bracket for PHOBOS BT / PHOBOS BT L

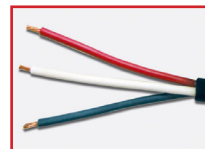

D141297

Spare 3' (1m) cable
Cable for PHOBOS BT
3 core wire

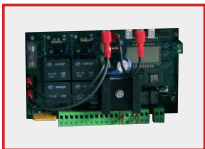

D111665 00003 - LIBRA UL R BOARD ONLY

Replacement board.



D111904 Mitto 2 Transmitter:

12V Two channel 433Mhz rolling code remote control

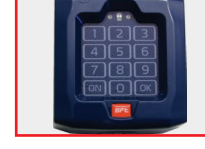

P121024 - Q-BOX

Digital keypad with 10 channels and 100 combinations. Backlit



KED113731H - ECOSOL KIT

Includes Ecosol Interface, solar panel and 15' solar of panel cable, connection harness for easy installation, for running BFT control panels off 24V solar power. Includes two 12V 7.2Ah batteries and circuit board for management of commands to control panel and battery charge management, with built-in Rolling Code 433.92 MHz receiver with 63 stored positions.

- T: US. 1877 995 8155
- info.bft@bft-usa.com
- www.bft-usa.com



tuned to you

BFT Americas, Inc.

6100 Broken Sound Parkway N.W.,
Suite 14
Boca Raton, FL, 33487