

- I** AUTOMAZIONI A BRACCIO PER CANCELLI A BATTENTE
- GB** ARM AUTOMATIONS FOR SWING GATES
- F** AUTOMATIONS A BRAS POUR PORTAILS BATTANTS
- D** ARM AUTOMATIONEN FUER FLUGELGITERTIRE
- E** AUTOMATIZACIONES A BRAZO PARA PORTONES CON BATIENTE
- P** AUTOMATIZAÇÕES DE BRAÇO PARA PORTÕES DE BATENTE

**E5**

ISTRUZIONI D'USO E DI INSTALLAZIONE
INSTALLATION AND USER'S MANUAL
INSTRUCTIONS D'UTILISATION ET D'INSTALLATION
MONTAGE- und BEDIENUNGSANLEITUNG
INSTRUCCIONES DE USO Y DE INSTALACION
INSTRUÇÕES DE USO E DE INSTALAÇÃO



AZIENDA CON SISTEMA QUALITÀ
CERTIFICATO DA DNV
=UNI EN ISO 9001/2000=

Via Lago di Vico, 44
 36015 Schio (VI)
 Tel.naz. 0445 696511
 Tel.int. +39 0445 696533
 Fax 0445 696522
 Internet: www.bft.it
 E-mail: sales@bft.it

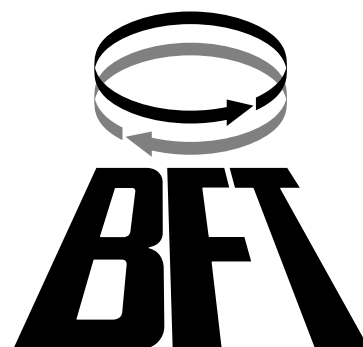

Thank you for buying this product. Our company is sure that you will be more than satisfied with the product's performance. Carefully read the "WARNINGS" pamphlet and the "INSTRUCTION BOOKLET" which are supplied together with this product, since they provide important information regarding the safety, installation, use and maintenance of the product.

This product complies with recognised technical standards and safety regulations. We declare that this product is in conformity with the following European Directives: 89/336/EEC, 73/23/EEC and following amendments.

1) GENERAL OUTLINE

The E5 model consists of a compact electromechanical gearmotor with minimum overall dimensions which can be installed on any post or pillar thanks to its versatility. Gate locking in the closing position is guaranteed by an electric lock. The reversibility of the gearmotor allows immediate manual manoeuvring of the gate in case of emergency, by means of the appropriate personalised key releasing the electric lock. Total anti-squash safety is provided by a multiple-disk clutch and the end-of-stroke operation is set by a timer.

The gearmotor (fig.1) is made up of : Motor single-block "M", Epicycloidal reducing gear "R", Multiple-disk mechanical clutch "F", Pushing arm "B".

2) TECHNICAL SPECIFICATIONS

Power supply	230V~ ±10% 50Hz single-phase (*)
Motor	1400 min ⁻¹
Max. power	200W
Reduction ratio	1/1296
Capacitor	8µF
Absorbed current	0,8A
Lubrication	Permanent grease
Max. torque	300 Nm
Opening speed	22 s (~ 6,5 °/s)
Max. leaf weight	2000N (~200kg)
Max. leaf length	1.800mm
Max opening degrees	130° 180° with slide arm
Impact reaction	Multiple-disk mechanical clutch
Manual manoeuvre	Electric lock release with key
No. manoeuvres in 24 h	50
Environmental conditions	-10°C to +60°C
Degree of protection	IP 44
Controller weight	8 kg
Dimensions	See fig.2

(*) Special voltages on request

3) INSTALLATION OF THE ACTUATOR

3.1) Preliminary checks

Check:

- That the structure of the gate is strong enough. The fixing position must be determined according to the leaf structure. In any case, the drive arm must push against a reinforced point in the leaf;
- That the leaves can be moved manually without excessive effort for the whole of their stroke;
- If the gate being installed is not new, check whether its components are worn.

Repair or replace any worn or damaged parts.

Automation reliability and safety are directly influenced by the condition of the gate structure.

3.2) Standard installation

Fig. 3 shows the standard installation position for Mod. E5. However, if the automation must be fitted onto a gate with a pedestrian access and with a leaf with up to 1.4 m length, the opening speed can be increased by bringing the gate fastening position "A" near to the hinge-pivot (fig.4) or by shortening the articulated lever "L2" (fig.5).

If the minimum value equal to 210mm indicated in the drawing of fig.6 is not available due to the presence of a wall in the corner, use a slide arm (fig.7); in this case, make sure that the length of the leaf does not exceed 1.6 metres and its weight is 100 kg max.

If the maximum value equal to 200mm (fig.3) is not available due to a too large gate-post, use version E5L with both arms "L1-L2" extended (fig.8). For heavy gates with leaves with up to 2 m length 200 kg weight, request an extended "L2" arm (fig.9) featuring increased power; in this case, the opening time will be longer because the rotation degrees of lever "L1" are increased. If the automation must be fitted onto a gate with 180° angular opening (fig.10) or there is no space in the gate-post to mount the motor, a recess should be made in the leaf in correspondence with the gate hinge-pivot (fig.11); in this case the weight of the leaf must not be supported by the gearmotor and the length of the single leaf must not exceed 1.6 m and

its weight not be greater than 100 kg.

WARNING! The controller mod. E5 must not be installed with the clutch unit facing downward.

4) FITTING OF THE GERMOTOR

To fit the gearmotor supporting plate onto the gate-post proceed as follows:

- With a good electric welding (fig. 12) if the gate-post is made of metal.
- If the gate-post is in brick, the plate must be set soundly into the post using adequately sized cramps "Z" welded to the back of the plate (fig. 13).
- If the gate-post is in stone and the gate is small and therefore does not require excessive power to be opened, the plate can be mounted with four metal expansion plugs "T" (fig. 14).
- If the gate-post is in stone and a large gate is being installed it would be better to weld the plate to a corner plate "C" fixed with four expansion plugs (fig. 15).
- After fastening the anchoring plate, fit the gearmotor (fig. 16).
- Close the gate and loosen the clutch (fig. 23). Position the drive arm so as to create a pressing angle as shown in the figures for positioning.
- Temporarily lock the fastening element "A" (fig. 17) to the leaf (using locking pliers) and open the leaf manually. Check that the drive arm does not cause any crushing or entanglement risks when moving.
- Secure the fastening fork "A" to the leaf (fig. 17) using the four threaded holes "F" to be made in the selected position.
- Check that the arm is level (fig. 18).
- In the case of gearmotors equipped with the slide arm Mod. E5S, the slide "S" should be secured with its sliding slit facing the ground (fig. 19); the slide must be located at the maximum distance from the gate-post allowed by the arm "L1".

5) FITTING THE ELECTRIC LOCK

Due to the reversibility of the gearmotor, an electric lock must be fitted. The company supplies a special electric lock Mod. EBP (fig. 20) which consists of a continuous electromagnet with ground catch. This device remains energised during the total operation time of the gearmotor so as the bolt "D" can reach the closing limit stop lifted without creating any friction with the ground and guaranteeing a smooth movement.

If the gates has two leaves, the leaf equipped with the electric lock should close last.

Use a control unit with closing delay adjustment for the second leaf.

6) GATE STOP LIMITS

It is compulsory to fit the gate stop limits "F" (fig.21), both in opening and closing positions, to stop the strokes of the leaves in the desired positions.

7) ELECTRICAL PLANT SET-UP

Set the electrical plant as shown in fig. 22 according to the current standards for electrical plants CEI 64-8, IEC364, Harmonization HD384 and other national regulations. Keep the power supply connections definitely separated from the auxiliary connections (photocells, control devices, etc.). Fig. 22 indicates the number of connections and the sections for 100 m. long power supply cables. For distances of over 100 m., calculate the cable section depending on the automation actual load.

The automation main components are the following (fig. 22):

- I** Type approved omnipolar switch with 3 mm min. contact opening provided with overload and short-circuit protection, used to break the automation connection from the mains. If not present, provide the automation with a type approved differential switch with adequate capacity and a 0.03 A threshold.
- QR** Control unit with built-in receiver
- SPL** Pre-heating board on the control panel for operation at temperatures below -10° C (optional)
- S** Key selector
- AL** Blinker tuned in with antenna
- M** Actuators
- E** Electric lock
- Fte, Fre** Pair of outside photocells
- Fti, Fri** Pair of inside photocells with columns
- T** 1-2-4 channel transmitter

WARNING! For the connection of the accessories, please refer to the relevant instruction manuals. The type of control boards and accessories must be suitable for the intended use and in compliance with the current safety standards.

8) MOTOR TORQUE ADJUSTMENT (CLUTCH)

The motor torque adjustment is carried out in the gearmotor by means of

the mechanical multiple-disk clutch (fig.23).

The adjustment of the clutch must be carried out by qualified personnel (installer) and includes the calibration of the clutch to the minimum force needed to complete full opening and closing strokes. The calibration must never exceed the values of the pushing force measured on the leaf edge according to the national standards in force. In Italy the admitted value is equal to 150N.

WARNING! Do not secure completely the adjustment screw of this device; this could compromise the safety of the automation and the controller could get damaged.

Carry out the adjustment as follows:

Remove the cover "A" and rotate from time to time small sections of the screw "C" using the appropriate spanner "B". To tighten the clutch, rotate the screw clockwise (towards +), to loosen the clutch, rotate the screw anticlockwise (towards -).

Carry out the adjustment on every controller mounted and refit the cover "A". Fig.24 indicates the assembly sequence for the clutch components: A) cover, C) adjustment screw, E) Belleville washer, F) clutch disks with inside keying, G) clutch disks with outside keying, H) arm, I) shim washer, L) grooved reduction shaft.

9) LIMIT SWITCHES

The controllers are not equipped with electric limit switches. For this reason, they must be controlled by a control unit with adjustment of the operation time. When the leaf reaches the gate stop limit the clutch slides and the motor remains energised until the total operation time set has elapsed. The operation time can be set on the control unit by means of a trimmer. The time is correct when the time set is 3-5 seconds greater than the actual time needed to complete one full opening and closing cycle. If the leaf is too slow, adjust the operation time in closing position. The less the movement time at the end of stroke is, the longer the clutch life will be. If external electric limit switches are used, refer to the two different installation methods in fig.25-26. The limit switches must be sealed. To connect the limit switches, refer to the instructions for the control unit.

10) EMERGENCY MANOEUVRE

Since the gearmotor is reversible, release the electric lock and move the leaves manually in the case of a power failure. When the power supply has been restored, the automation operates automatically.

11) CHECKING THE AUTOMATION

Before considering the automation completely operational, the following checks must be made with great care:

Check that all the safety means work properly (i.e. clutch, photocells, pneumatic skirts, etc.).

Check that the thrust (anti-squash) of the leaf is within the limits prescribed by the standards in force.

Check the manual opening control.

Check the opening and closing manoeuvres using the controls.

Check the control unit's electronic logic in normal or customised operation.

12) USE OF THE AUTOMATION

Since the automation may be remote controlled either by radio or a start button (and therefore not visually), it is essential that all safeties are checked frequently.

Any malfunction should be corrected immediately by qualified personnel. Keep children at a safe distance from the field of action of the automation.

13) THE CONTROLS

With the automation the gate has a power driven opening and closing. The controls can come in various forms (i.e. manual, remote controlled, limited access by magnetic badge, etc.) depending on needs and installation characteristics. For details on the various command systems, consult the specific instruction booklets.

Anyone using the automation must be instructed on its operation and controls.

14) MAINTENANCE

All maintenance operations must be performed with the system power supply shut off.

Lubricate periodically the articulated elements of the drive arm.

Clean the optical system of the photocells every now and then.

Have the adjustment of the electric clutch checked by a qualified specialist (installer).

For any malfunction that remains unsolved, shut off the power to the system and call a qualified specialist (installer).

15) NOISE

The aerial noise produced by the gearmotor under normal operating conditions is constant and does not exceed 70dB(A).

16) SCRAPPING

Materials must be disposed of in conformity with the current regulations. In case of scrapping, the automation devices do not entail any particular risks or danger. In case of recovered materials, these should be sorted out by type (electrical components, copper, aluminium, plastic etc.).

17) DISMANTELLING

When the automation system is disassembled to be reassembled on another site, proceed as follows:

- Disconnect the power supply and the entire electrical installation.
- Remove the gearmotor from its fixing base.
- Disassemble the control panel, if separate, and all installation components.
- In the case where some of the components cannot be removed or are damaged, they must be replaced.

18) TROUBLESHOOTING

18.1) The gate does not open. The motor runs, but the opening movement does not start.

- 1) Check if the electric lock works correctly.
 - 2) Check if the mechanical arrangement of the gate is faulty, e.g. there are interferences with the gate stop limits or between the edges of the leaves.
 - 3) Check if the clutch slides and, if necessary, tighten it by rotating the screw towards the + sign (max. thrust allowed 150N).
 - 4) If the motor runs in the direction opposite to the right one, invert the driving connections of the motor (check rotation by lifting the clutch cover).
- If after having carried out the checks listed above the problem persists, replace the controller.

18.2) The gate does not open or close. The motor does not run and no sound is heard.

- 1) Check that the control unit is correctly powered.
 - 2) Check that the photocells or the rubber skirts are not engaged.
 - 2) Check that the electronic equipment is correctly powered. Check that the fuses are not damaged.
 - 4) Check that the electronic functions of the equipment are correct by means of the diagnostic LEDs or through a visual inspection.
 - 5) Check that no remote controls, start buttons or other devices are keeping the start contact (N.C.) closed.
- If after having carried out the checks listed above the problem persists, replace the control unit.

18.3) The noise originating from the motor is high when the leaf encounters the gate stop limit.

- 1) When the clutch slides because the leaf has reached the gate stop limit, the leaf must be still and no oscillations should be noticed. If jog movements are noticed, reinforce the leaf so as to eliminate the problem.
- 2) If the leaf cannot be reinforced, decrease the working time so that the clutch slides as little as possible.
- 3) If the disks are bright, restore them with sandpaper or, if necessary, replace them.

The descriptions and illustrations contained in the present manual are not binding. The Company reserves the right to make any alterations deemed appropriate for the technical, manufacturing and commercial improvement of the product, while leaving the essential product features unchanged, at any time and without undertaking to update the present publication.

Fig. 1

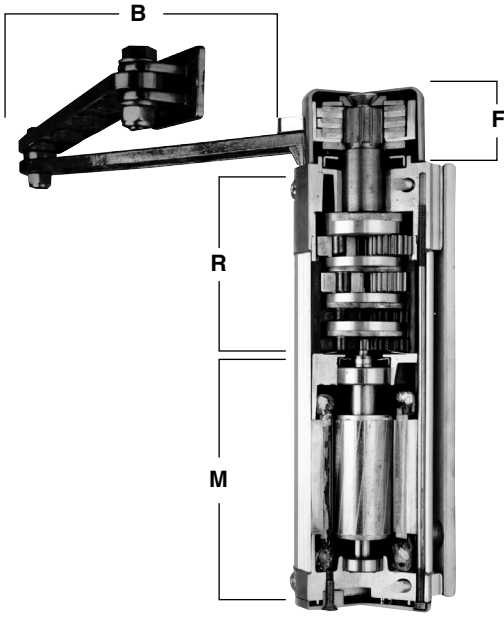

Fig. 2

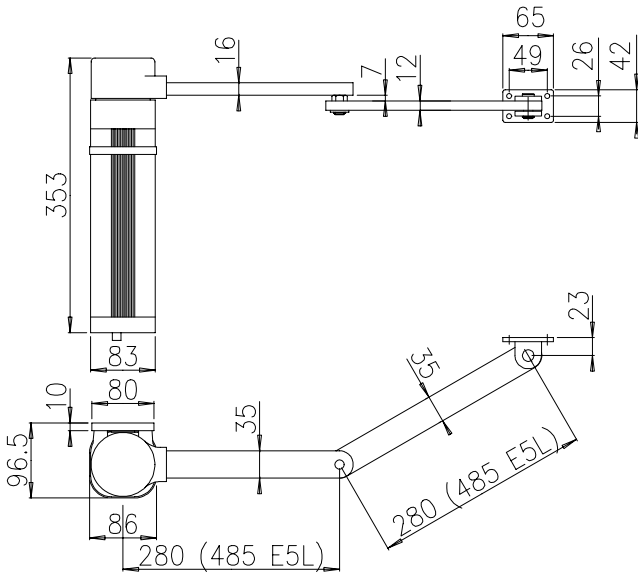

Fig. 3

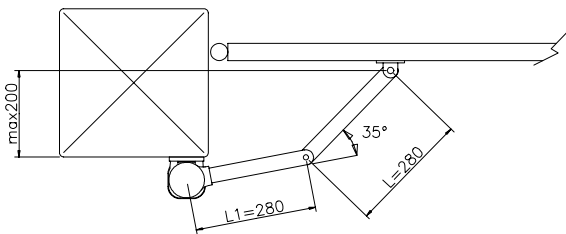

Fig. 4

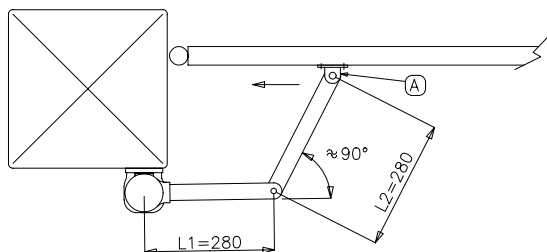

Fig. 5

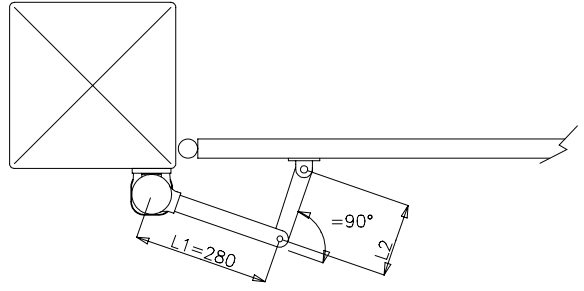

Fig. 6

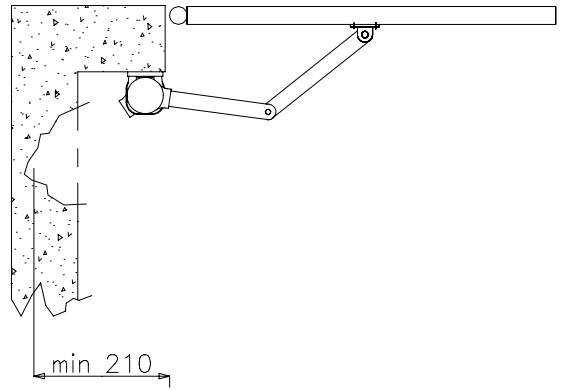

Fig. 7

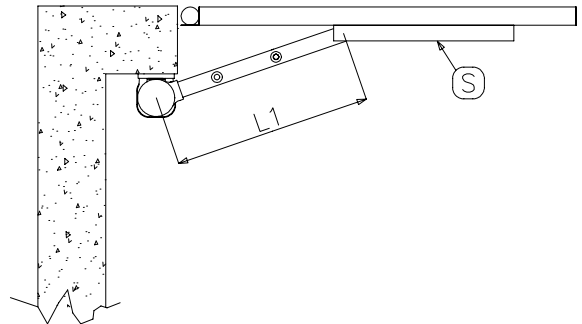

Fig. 8

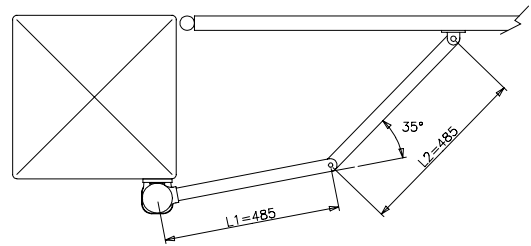

Fig. 8

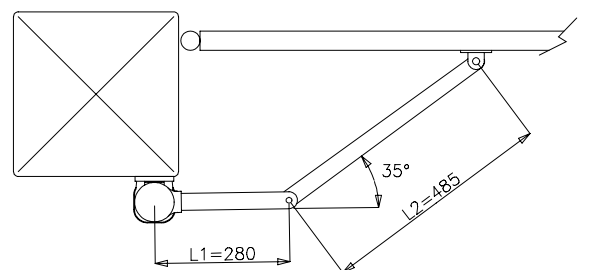

Fig. 10

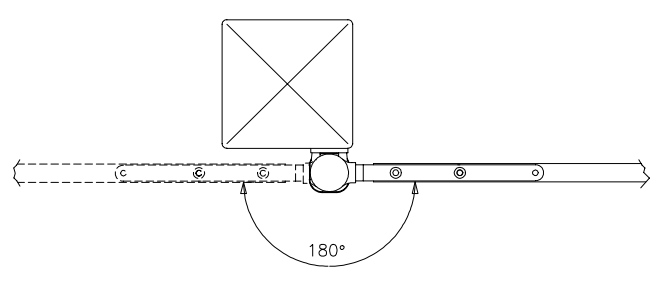

Fig. 17

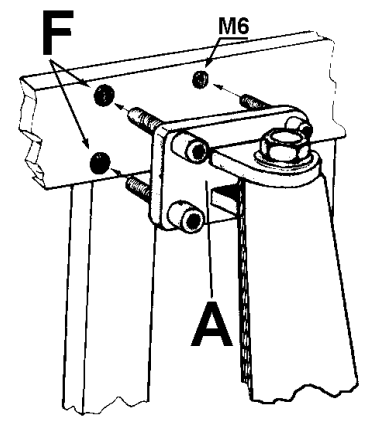

Fig. 11

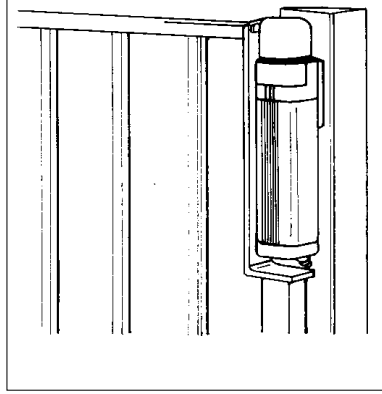

Fig. 12

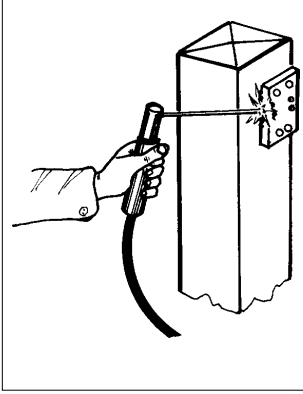

Fig. 18

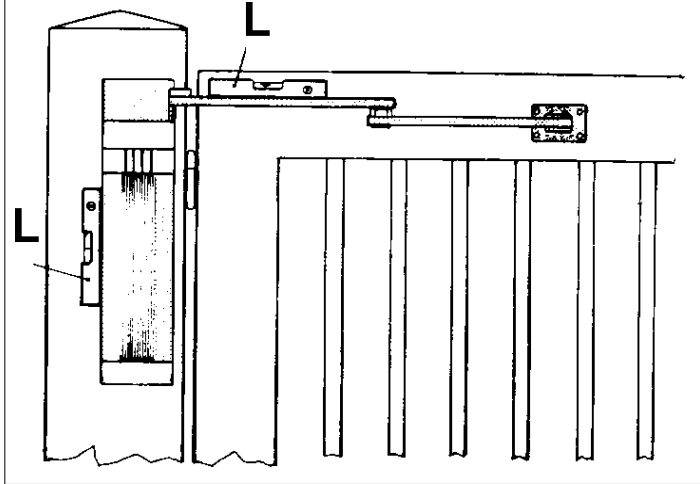

Fig. 13

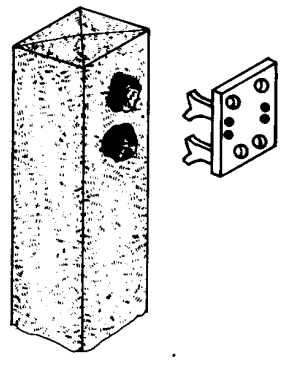

Fig. 14

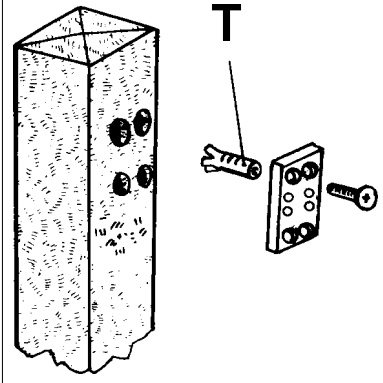

Fig. 19

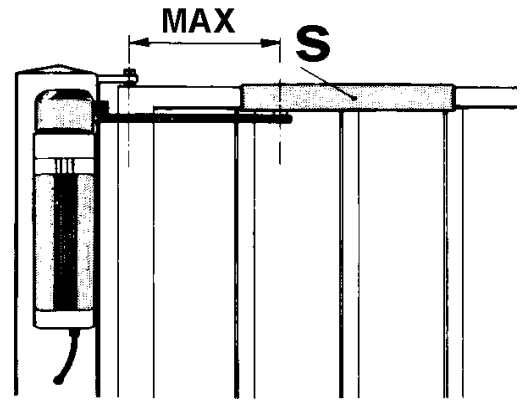

Fig. 16

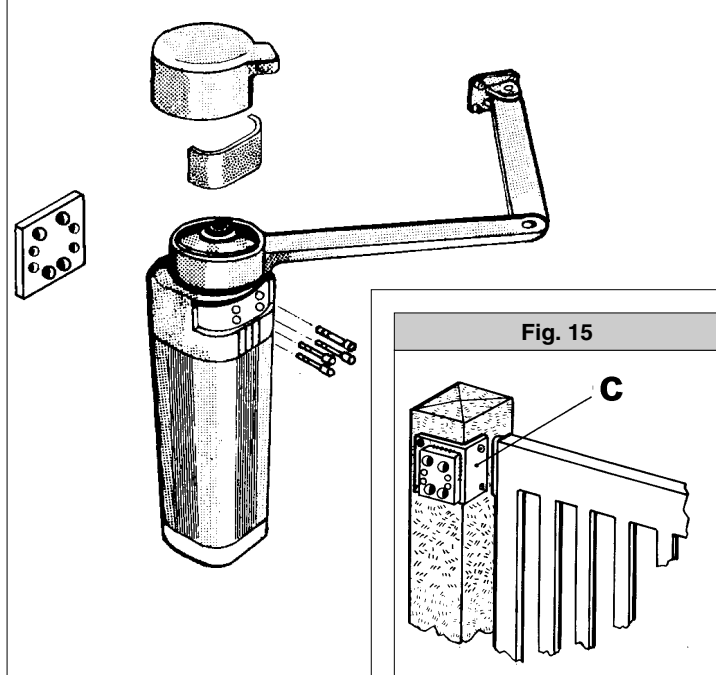

Fig. 15

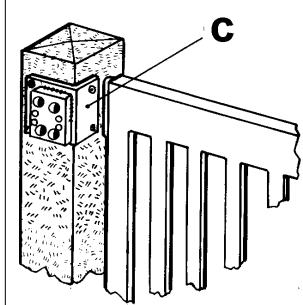

Fig. 20

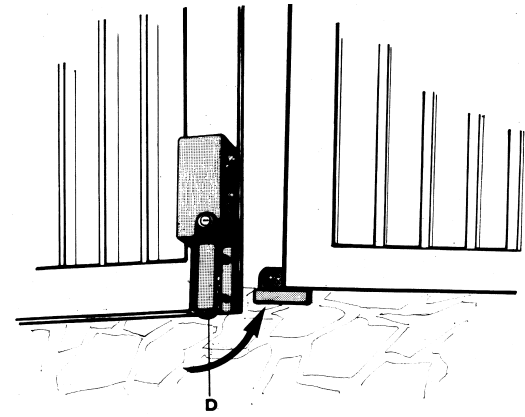

Fig. 21

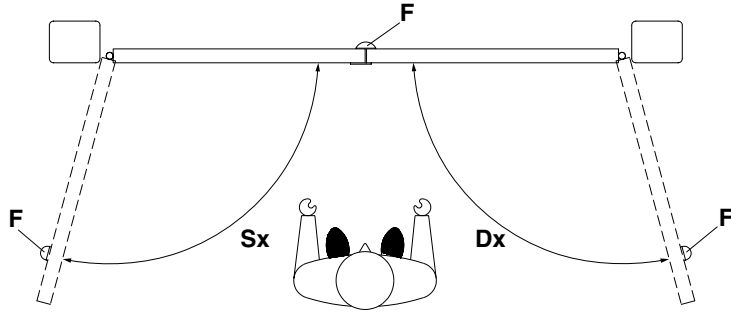

Fig. 22

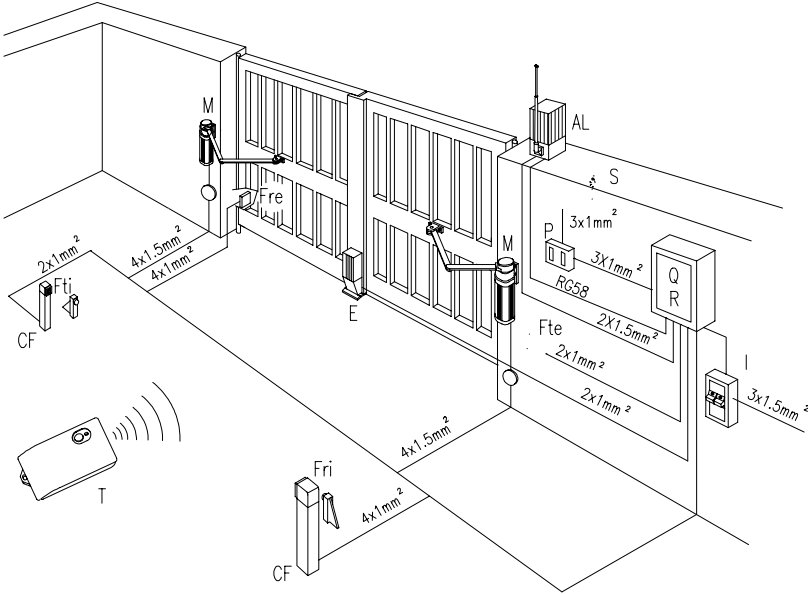

Fig. 23

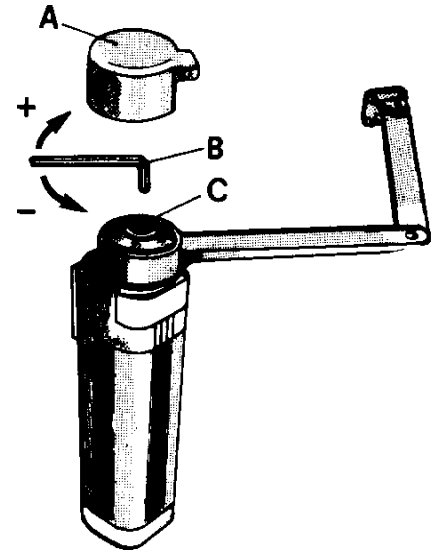

Fig. 24

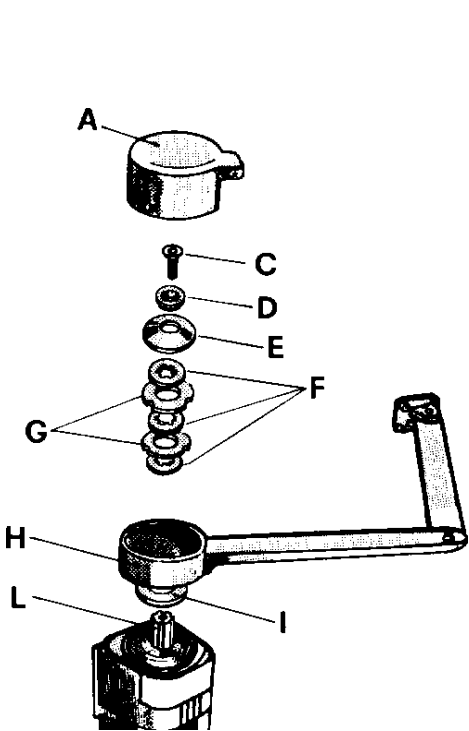

Fig. 25

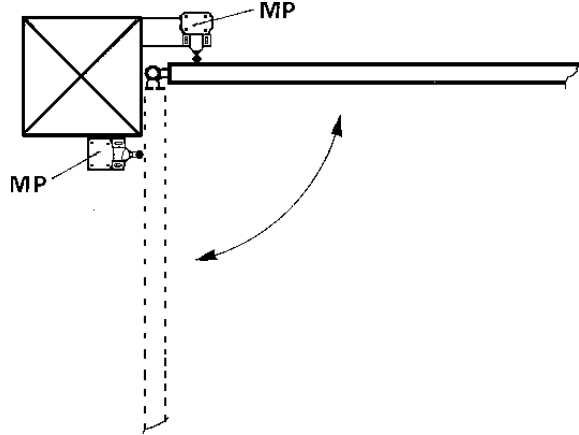

Fig. 26

