



Be ahead



SP3500





Sliding gate automation systems

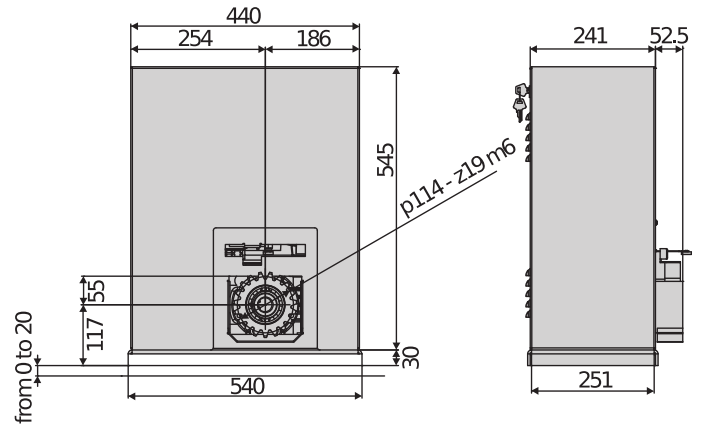

Powerful, robust operators with 400V three-phase power supply designed specifically for large, heavy gates. The heavy structure of the gear motor, the painted galvanised steel casing and the on-board control unit make it the ideal solution for all industrial situations where reliability and power are essential.

Relevant features



Travel limits can be adjusted simply with the lever arm electromechanical limit switch system, giving absolute precision in stopping.



The powerful electric brake allows to block the leaf after the closing operations, guaranteeing a perfect closure even in sloped installations.



Sliding gate automation systems



SP3500

Code	Ci	Name	Description	
P925207 00002	2601301	SP3500 TRI 230	Operator 230 V for sliding gates weighing up to 3500 kg. Leaf speed 10,5 m/min. U-link and limit switch Electromechanical. Three-phase power supply 230 V. Fixing base included. Control unit with display and U-Link communication protocol	U-Link
P925207 00001	2600514	SP3500 TRI 400	Operator 400 V for sliding gates up to 3500 kg in weight. Gate speed 10 m/min. U-link and limit switch Electromechanical. Three-phase 400 V power supply. Anchorage base included. Operator with mechanical brake Electromechanical limit switch. Control unit with display, preconfigured for communication with U-Link protocol	U-Link

	SP3500 TRI 230	SP3500 TRI 400
Control unit	SIRIO CBB	SIRIO CBB
Board power supply	230 V	400 V
Motor voltage	230 V	400 V
Power consumption	550 W	550 W
Max. door/gate weight	3500 kg	3500 kg
Gate panel speed	10,5 m/min	10 m/min
Type of limit switch	Electromechanical	Electromechanical
Pinion module	6	6
Slowdown	no	no
Locking	Mechanical	Mechanical
Release	Hex key	Hex key
Impact reaction	Sensitive edge	Sensitive edge
Frequency of use	very intensive	very intensive
Protection rating	IP54	IP54
Environmental conditions	-15 + 50 °C	-15 + 50 °C

RECOMMENDED ACCESSORIES

	Cp P111468 - Ci 2600811 B EBA RS 485 LINK		Cp D114093 00002 - Ci 2607538 RADIUS LED AC A R1
Expansion board for connection of central units with serial controls management		Flashing light with incorporated antenna for motors with 230 V power supply.	
	Cp P111782 - Ci 2601411 COMPACTA A20-180		Cp D571491 - Ci 2600074 CFZ6
Pair of photocells adjustable 180° horizontally. 20 metre range. 12-33 VAC/15-35 VDC power supply.		galvanized steel rack, 6-module, cross-section 30 x 30 mm, length 2 m, welding attachment Max. load capacity 4000 kg.	



SP3500



Sliding gate automation systems



Empowered by
U-LINK

EasyAXS

EASY CONNECT. EASY ACCESS.



The new connectivity solution which boosts the potential of BFT products and services to make access automations smarter and easier to use for both installers and end users.





Sliding gate automation systems



EASY TO CONNECT

WIFI MODULE



→ 10/15 metres

WIFI MODULE + ANTENNA



→ 20/25 metres

MOBILE MODULE + ANTENNA + SIM



→ ∞



**PLUG&PLAY
INSTALLATION**



**ALWAYS
CONNECTED**



**EVEN MORE
CONNECTIVITY**



**EASY TO SET UP
FOR INSTALLERS**



**EASY TO CONTROL
FOR CUSTOMERS**





Sliding gate automation systems

Empowered by
U-LINK

U-LINK 2.0

AN UPDATED VERSION OF
U-LINK TO GIVE YOU EVEN
MORE FUNCTIONALITY



Scalable

You can add as many devices as you want



Intuitive

Easy to install and to use



Functional

Settings can be controlled and firmware updated remotely using dedicated applications



Practical

Works with or without an internet connection



Flexible

It allows you to create groups of interconnected products

U-Link, the exclusive **BFT** technology platform has evolved to offer improved interaction with the latest generation of technological ecosystems. Its ability to interface with all home access automation access devices has been expanded, meaning it is now a very useful tool for installers. It is also a faster communication protocol with increased security for communicating information.

It allows you to save even more time, checking everything very easily and giving you even more peace of mind.



Sliding gate automation systems

Empowered by
U-LINK

U-SECURITY

A NEW AND EVEN MORE SECURE RADIO PROTOCOL



→ **Secure**

By transmitting data protected by a cryptographic key

U-Security is the new technology from **BFT** which incorporates encrypted rolling code thanks to the encryption key which masks the remote control code, meaning that it is impossible to clone a BFT remote control using another brand's model.

The functions of the **Er Ready** system are incorporated and a new procedure is also available for programming remote controls by scanning a QR CODE and using a special app. All products featuring this technology are **REPLAY**, so they can transmit the code to another BFT remote control using a combination of keys.



→ **Easy**

Pairing a remote control with a receiver can be done easily by scanning the QR code and using the dedicated app



→ **Universal**

The radio protocol is also compatible with the previous generation of receivers

