

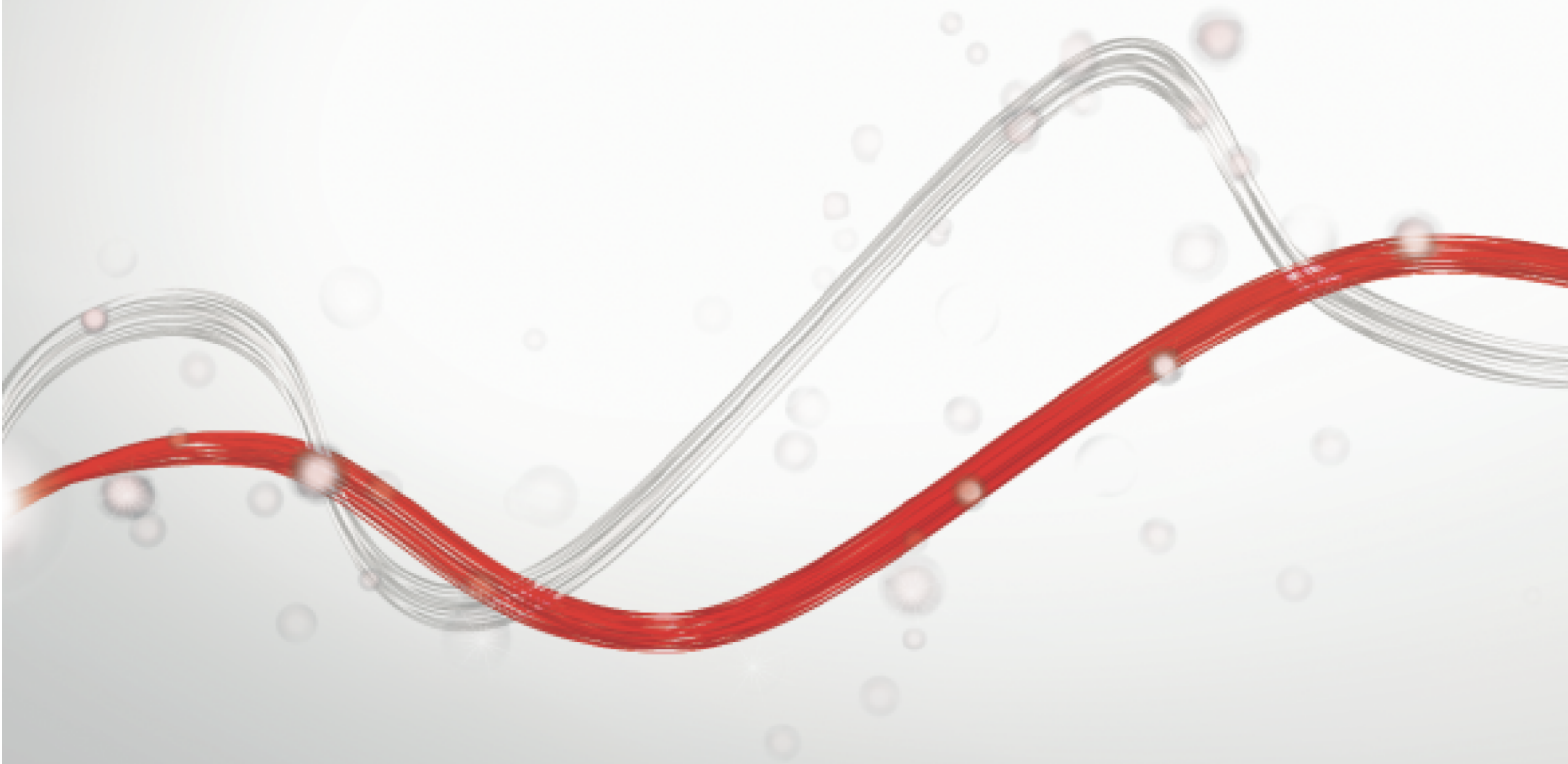

Be ahead

PILLAR B 275/800.6C





PILLAR B 275/800.6C



Parking and traffic bollards

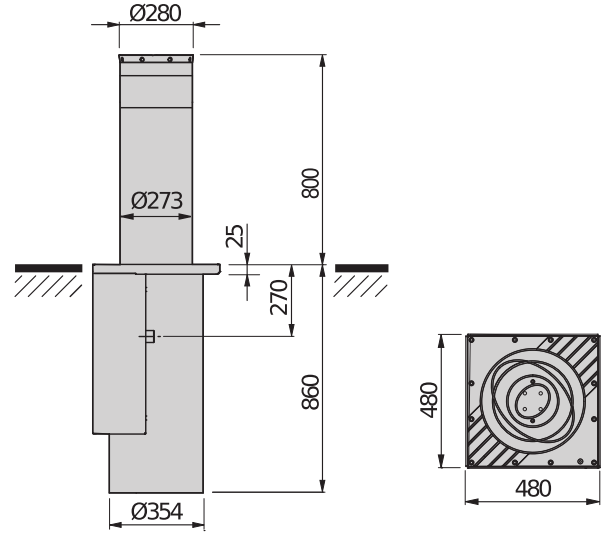

Automatic high strength anti-terrorism hydraulic bollard with incorporated hydraulic control unit. Suitable for protecting sensitive sites, thanks to the special "SD" version, which keeps the shaft raised in case of a power failure and with public installations where, in the standard version, the shaft lowers automatically when the power is cut.

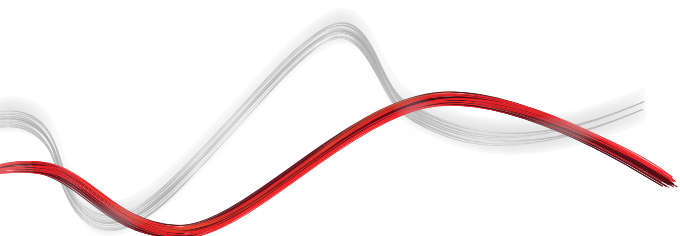



Parking and traffic bollards

PILLAR B 275/800.6C

Code	Ci	Name	Description
P970093 00001	2601346	PILLAR B 275/800.6C L	230 V hydraulic bollard, shaft height 800 mm and diameter 273 mm. In the event of a power cut, the bollard lowers automatically. Painted stainless steel version, RAL 7015. Foundation box included. LED light cap.
P970093 00302	2600994	PILLAR B 275/800.6C LI STAINLESS STEEL 316	230 V hydraulic bollard, shaft height 800 mm and diameter 273 mm. In the event of a power cut, the bollard lowers automatically. Foundation box included. LED lights cap, AISI 316L stainless steel version.
P970093 00003	2601347	PILLAR B 275/800.6C L SD	Hydraulic bollard 230 V, shaft height 800 mm and diameter 273 mm. LED light cap and H adhesive strip: 100 mm approved. The shaft stays raised in case of a power failure. RAL 7015 painted steel version. LED light cap. Security & Device version.
P970093 00304	2605584	PILLAR B 275/800.6C LI SD STAINLESS STEEL 316	230 V hydraulic bollard, shaft height 800 mm and diameter 273 mm. LED light cap and H adhesive strip: 100 mm, certified. In the event of a power cut, the bollard remains raised. Foundation box included. LED light cap. Security & Device version. AISI 316L stainless steel version.

PERSEO CBE 230.P SD: Control unit with built-in U-Link, receiver and heating circuit (up to -40°C) for electromechanical and hydraulic bollards. You can manage up to 4 bollards at the same time (maximum 1 XPASS 330/1200 or 2 XPASS B 275/800 EFO)



Cp D113812 00002 - Ci 2600139 - PERSEO CBE 230.P SD - Recommended



- Control unit with built-in U-Link, receiver and heating circuit (up to -40°C) for electromechanical and hydraulic bollards. You can manage up to 4 bollards at the same time (maximum 1 XPASS 330/1200 or 2 XPASS B 275/800 EFO)
- Application: Control panel for operating 1 to 4 automatic bollards, single-phase (in parallel) (maximum 1 XPASS 330/1200 or 2 XPASS B 275/800 EFO)
- Board power supply: 230V single phase
- Output power: 230Vac single-phase, 12A max.
- Main features: removable terminal blocks, digital programming, 3-digit display, Proxima programmer connector, dual-channel receiver 2048 codes included, heater for operation to -40°C, complete support for anti-terrorism bollards, 11 inputs, 9 outputs.
- Main features: U-Link interconnectivity, automatic reclosing, separate open and close, pre-flashing, deadman control, automatic or semi-automatic, opening and closing limit switch management, arranged for UPS.

	PILLAR B 275/800.6C L	PILLAR B 275/800.6C LI STAINLESS STEEL 316	PILLAR B 275/800.6C L SD	PILLAR B 275/800.6C LI SD STAINLESS STEEL 316
Rise time	6,1 s	6,1 s	6,1 s	6,1 s
Lowering time	5 s	5 s	5 s	5 s
Rod height	800 mm	800 mm	800 mm	800 mm
Rod diameter	273 mm	273 mm	273 mm	273 mm
Rod thickness	6 mm	6 mm	6 mm	6 mm
Power supply	230 V	230 V	230 V	230 V
Control unit	PERSEO CBE	PERSEO CBE	PERSEO CBE	PERSEO CBE
Impact resistance	20000 J	20000 J	20000 J	20000 J
Break-in proof	250000 J	250000 J	250000 J	250000 J
Manual cycle	reversible in the absence of voltage	reversible in the absence of voltage	Release key	Release key
Frequency of use	3000 Op/gg	3000 Op/gg	3000 Op/gg	3000 Op/gg
Type of limit switch	REED magnetic sensor	REED magnetic sensor	REED magnetic sensor	REED magnetic sensor
Rod treatment	RAL7015 cataphoresis coating and paint	AISI 316L stainless steel	RAL7015 cataphoresis coating and paint	AISI 316L stainless steel
Environmental conditions	-40 ÷ 60 °C	-40 ÷ 60 °C	-40 ÷ 60 °C	-40 ÷ 60 °C
Protection rating	IP67	IP67	IP67	IP67



PILLAR B 275/800.6C



Parking and traffic bollards

RECOMMENDED ACCESSORIES

	Cp P800114 - Cj 2605291 BOLLARD CABLE EXT25 Extra charge for 25 m cable for bollards (to be added to the 10 included into bollards)				
--	---	--	--	--	--

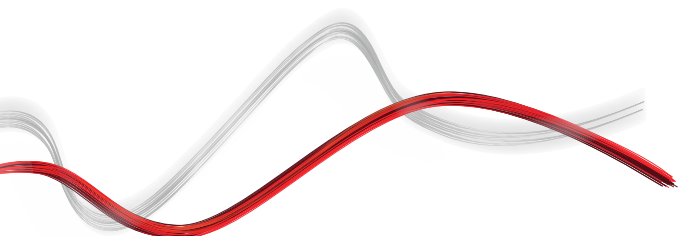



Parking and traffic bollards

EasyAXS

EASY CONNECT. EASY ACCESS.



The new connectivity solution which boosts the potential of BFT products and services to make access automations smarter and easier to use for both installers and end users.





Parking and traffic bollards

EASY TO CONNECT

WIFI MODULE



→ 10/15 metres

WIFI MODULE + ANTENNA



→ 20/25 metres

MOBILE MODULE + ANTENNA + SIM



→ ∞



**PLUG&PLAY
INSTALLATION**



**ALWAYS
CONNECTED**



**EVEN MORE
CONNECTIVITY**



**EASY TO SET UP
FOR INSTALLERS**



**EASY TO CONTROL
FOR CUSTOMERS**





Parking and traffic bollards



U-LINK 2.0

AN UPDATED VERSION OF **U-LINK** TO GIVE YOU EVEN MORE FUNCTIONALITY



Scalable

You can add as many devices as you want



Intuitive

Easy to install and to use



Functional

Settings can be controlled and firmware updated remotely using dedicated applications



Practical

Works with or without an internet connection



Flexible

It allows you to create groups of interconnected products

U-Link, the exclusive **BFT** technology platform has evolved to offer improved interaction with the latest generation of technological ecosystems. Its ability to interface with all home access automation access devices has been expanded, meaning it is now a very useful tool for installers. It is also a faster communication protocol with increased security for communicating information.

It allows you to save even more time, checking everything very easily and giving you even more peace of mind.



Parking and traffic bollards

-SECURITY

A NEW AND EVEN MORE SECURE RADIO PROTOCOL



Secure

By transmitting data protected by a cryptographic key

U-Security is the new technology from **BFT** which incorporates encrypted rolling code thanks to the encryption key which masks the remote control code, meaning that it is impossible to clone a BFT remote control using another brand's model.

The functions of the **Er Ready** system are incorporated and a new procedure is also available for programming remote controls by scanning a QR CODE and using a special app. All products featuring this technology are **REPLAY**, so they can transmit the code to another BFT remote control using a combination of keys.



Easy

Pairing a remote control with a receiver can be done easily by scanning the QR code and using the dedicated app



Universal

The radio protocol is also compatible with the previous generation of receivers



INFORMATION REGARDING THE PROTECTION OF THE INDUSTRIAL AND INTELLECTUAL PROPERTY RIGHTS OF BFT. BFT S.p.A. protects its industrial property by depositing trademarks, patents, models and designs. The intellectual property of BFT S.p.A. is protected by copyright law. BFT S.p.A. also protects its know-how by taking measures to protect the technical and commercial information inherent in its company and products. All the products in this catalogue are ORIGINAL BFT MODELS and only BFT S.p.A. is authorised to produce them and market them anywhere in the world. All the commercial names in this catalogue are owned by BFT S.p.A., and only BFT S.p.A. is authorised to use them in relation to the corresponding merchandise category. FALSIFIERS WILL BE PROCEEDED AGAINST IN ACCORDANCE WITH BOTH CIVIL AND CRIMINAL LAW. THESE CONDITIONS NOT ONLY GUARANTEE THE INTELLECTUAL PROPERTY RIGHTS OF BFT, BUT ALSO PROTECT CUSTOMERS BY GUARANTEEING THAT THE PRODUCTS THEY ARE PURCHASING ARE ORIGINAL BFT PRODUCTS RESULTING FROM STUDIES AND DESIGNS WITHIN THE BFT COMPANY.