



Be ahead



E5 BT A





E5 BT A



Electromechanical automation systems for swing gates

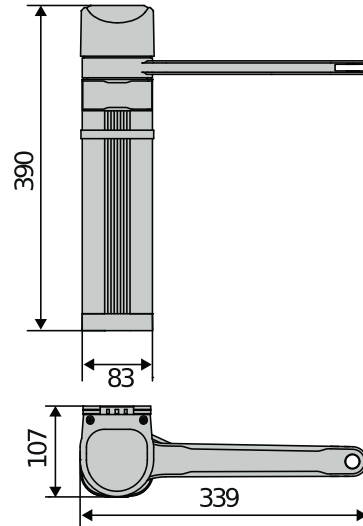

24V reversible electromechanical operator for swing gates for pedestrian and vehicular access, for use in homes and apartment buildings. Its small size means it can be installed on small pillars and columns (minimum width required 8cm). The slide arm option means constraints such as walls and obstacles close to the operator can be overcome. The limit switch function is regulated by the absolute encoder. The safety of the operator is guaranteed thanks to the D-track system which precisely determines the position and force with which the gate moves, using the friction inside the operator and the new articulated and slide arms with anti-shear design.

Relevant features



U-Link platform: Using the Thalia control unit, the E5 BT A operator is compatible with the U-Link communication protocol, the exclusive Bft connectivity platform.



d-track

D-Track dynamic path tracking: smart torque management system that constantly updates the gate torque level, improving the safety of the maneuver regardless of weather conditions, temperature or the degree of wear of the system.



Absolute Encoder: absolute encoder means that the E5 BT A recognises the position of the gate at any time, managing the slow down phase during opening and closing with absolute precision.



Easy Assembly

Ease of installation: the fixing bracket on the column or pillar provides simpler installation. The Thalia control unit has standardised colour terminal blocks which simplifies the identification of the outputs / inputs. The removable terminal blocks facilitate the wiring process. Extremely easy to set the closing and opening limit switches.



Electromechanical automation systems for swing gates



Relevant features



6,5 sec

Speed: The E5 BT A12 takes only 4.5 to 6.5 seconds (90 ° manoeuver including slowdown) to open, based on the weight and dimensions of the leaf.



push&go

Push&Go: When activated, the Push & Go function allows the gate to open completely when manually pushed.



Multi-resident or commercial sites: The E5 BT A12 is ideal for apartment block installations or public buildings, with features such as remote opening from inside the building and the ability to set the gate to close automatically after opening, preventing it being left open.



Electromechanical automation systems for swing gates



E5 BT A

Code	Ci	Name	Description	
P930027 00003	2601403	E5 BT A12	Reversible compact pedestrian electromechanical operator of small size that can be installed on pillars or columns only 80mm wide Application for pedestrian gates up to 1.2m wide and up to 80kg in weight Closes in 6.5s (ideal installation conditions) Operator with primary lever, to which the articulated arm or the short slide lever are added (accessories) Absolute encoder limit switch	U-Link
P930027 00001	2601404	E5 BT A18	Reversible compact vehicular electromechanical operator of small size that can be installed on pillars or columns only 80mm wide Application for vehicle gates up to 1.8m wide and up to 100kg in weight Operator with primary lever, to which the articulated arm or the long slide lever are added (accessories) Absolute encoder limit switch	U-Link
R930153 00003	2611897	E5 SMART BT KIT A12	24 V full kit for swing gates weighing up to 80 kg and up to 1.2 m long. Limit switch control via absolute encoder. Speed of operation between 4,5 and 6.5 seconds (including slowdown). Operator supplied with short slide lever.	
R930153 00001	2611896	E5 SMART BT KIT A18	24 V full kit for vehicle gates up to 100 kg in weight and 1,8 m wide. Limit switch control via absolute encoder. 14 second opening time (including slowdown) to 90°. The kit includes 2 operators with an articulated arm.	

	E5 BT A12	E5 BT A18
Control unit	THALIA BT A80, THALIA	THALIA BT A80, THALIA
Board power supply	230 V	230 V
Motor voltage	24 V	24 V
Max. weight of door/gate wing	80 kg	100 kg
Power consumption	100 W	100 W
Max. width of door/gate wing	1,2 m	1,8 m
Cycle time	6,5 s	14 s
Type of limit switch	Absolute encoder	Absolute encoder
Release	Reversible	Reversible
Impact reaction	D-Track	D-Track
Frequency of use	very intensive	Semi intensive
Frequency of use	100 Cicli/ora	20 Cicli/ora
Degree of protection (IP)	IP44	IP44
Environmental conditions	-20 ÷ 55 °C	-20 ÷ 55 °C

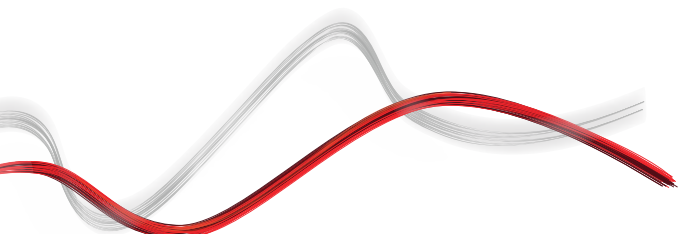



Electromechanical automation systems for swing gates



VITAL ACCESSORIES

	Cp D113745 00002 - Ci 2600477 THALIA		Cp D113747 00002 - Ci 2600583 THALIA P
	Cp N734921 - Ci 2601405 LBA		Cp N735057 - Ci 2601406 LS12
	Cp N735058 - Ci 2601407 LS18		

RECOMMENDED ACCESSORIES

	Cp D114093 00003 - Ci 2607539 RADIUS LED BT A R1		Cp D114168 00003 - Ci 2607544 RADIUS LED BT A R1 W
	Cp D114094 00003 - Ci 2607541 RADIUS LED BT A R0		Cp P111782 - Ci 2601411 COMPACTA A20-180
	Cp P125020 - Ci 2600844 BBT BAT		new Cp P123032 00003 - Ci 2613518 EBP BT A 24V

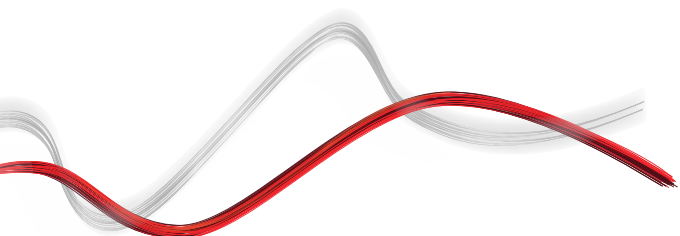



Electromechanical automation systems for swing gates



Empowered by
U-LINK

EasyAXS

EASY CONNECT. EASY ACCESS.



The new connectivity solution which boosts the potential of BFT products and services to make access automations smarter and easier to use for both installers and end users.

1



EASY TO CONNECT



PLUG&PLAY
CONNECTIVITY MODULE
FOR QUICKLY CONNECTING
BFT SOLUTIONS



2

EASY TO SET UP



CONFIGURATION
AND
MANAGEMENT OF
THE MOTOR WITH
THE **EasyAXS app**

3

EASY TO CONTROL



TaHoma app
TO PROVIDE CUSTOMERS
WITH A SMART SOLUTION
FOR ACCESSING THEIR
HOMES





Electromechanical automation systems for swing gates



EASY TO CONNECT

WIFI MODULE



→ 10/15 metres

WIFI MODULE + ANTENNA



→ 20/25 metres

MOBILE MODULE + ANTENNA + SIM



→ ∞



**PLUG&PLAY
INSTALLATION**



**ALWAYS
CONNECTED**



**EVEN MORE
CONNECTIVITY**



**EASY TO SET UP
FOR INSTALLERS**



**EASY TO CONTROL
FOR CUSTOMERS**





Electromechanical automation systems for swing gates



U-LINK 2.0

AN UPDATED VERSION OF
U-LINK TO GIVE YOU EVEN
MORE FUNCTIONALITY



Scalable

You can add as many devices as you want



Intuitive

Easy to install and to use



Functional

Settings can be controlled and firmware updated remotely using dedicated applications



Practical

Works with or without an internet connection



Flexible

It allows you to create groups of interconnected products

U-Link, the exclusive **BFT** technology platform has evolved to offer improved interaction with the latest generation of technological ecosystems. Its ability to interface with all home access automation access devices has been expanded, meaning it is now a very useful tool for installers. It is also a faster communication protocol with increased security for communicating information.

It allows you to save even more time, checking everything very easily and giving you even more peace of mind.



Electromechanical automation systems for swing gates



Empowered by
U-LINK

U-SECURITY

A NEW AND EVEN MORE SECURE RADIO PROTOCOL



→ **Secure**

By transmitting data protected by a cryptographic key

U-Security is the new technology from **BFT** which incorporates encrypted rolling code thanks to the encryption key which masks the remote control code, meaning that it is impossible to clone a BFT remote control using another brand's model.

The functions of the **Er Ready** system are incorporated and a new procedure is also available for programming remote controls by scanning a QR CODE and using a special app. All products featuring this technology are **REPLAY**, so they can transmit the code to another BFT remote control using a combination of keys.



→ **Easy**

Pairing a remote control with a receiver can be done easily by scanning the QR code and using the dedicated app



→ **Universal**

The radio protocol is also compatible with the previous generation of receivers



INFORMATION REGARDING THE PROTECTION OF THE INDUSTRIAL AND INTELLECTUAL PROPERTY RIGHTS OF BFT. BFT S.p.A. protects its industrial property by depositing trademarks, patents, models and designs. The intellectual property of BFT S.p.A. is protected by copyright law. BFT S.p.A. also protects its know-how by taking measures to protect the technical and commercial information inherent in its company and products. All the products in this catalogue are ORIGINAL BFT MODELS and only BFT S.p.A. is authorised to produce them and market them anywhere in the world. All the commercial names in this catalogue are owned by BFT S.p.A., and only BFT S.p.A. is authorised to use them in relation to the corresponding merchandise category. **FALSIFIERS WILL BE PROCEEDED AGAINST IN ACCORDANCE WITH BOTH CIVIL AND CRIMINAL LAW. THESE CONDITIONS NOT ONLY GUARANTEE THE INTELLECTUAL PROPERTY RIGHTS OF BFT, BUT ALSO PROTECT CUSTOMERS BY GUARANTEEING THAT THE PRODUCTS THEY ARE PURCHASING ARE ORIGINAL BFT PRODUCTS RESULTING FROM STUDIES AND DESIGNS WITHIN THE BFT COMPANY.**