

VIRGO

RANGE

Electromechanical operator for swing gates
up to 440 LBS and 6'6"

VIRGO

P930116 00001-with control board
P930117 00002 - without control board

SMART TECHNOLOGY

Built-in radio receiver

Incorporated positive stops and adjustable electric limit switches.

Separate programming of the two motors.

Control unit with self-learning and self-diagnostic functions.

Quick delayed motor reversing.



SAFE USE

- Specially designed for simpler and faster installation in compliance with latest safety standards.
- Thanks to the obstruction sensing device, the operator reverses motion and prevents damage to people and vehicles in the event of contact.
- Slows down during opening and closing.

TECHNICAL FEATURES

Control panel	LINX (incorporated)
Reversible/irreversible operator	irreversible
Power supply	120 V, 60 Hz single-phase
Absorbed power	0.05 hp (40 W)
Thermal protection	integrated in the control unit
Opening or closing time	14 s
Impact reaction	electronic torque limiter integrated in the control panel
Lock	mechanical on closing and opening
Manual release	release lever with key
Operating cycle	semi-intensive use
Environmental conditions	from 5°F (-15°C) to 122°F (+50°C)
Degree of protection	IP44
Operator weight	VIRGO 17 lbs (~8 kg) - VIRGO SQ 13 lbs (~6 kg)
Dimensions	see drawing next page

- T: US. 1877 995 8155
- info.bft@bft-usa.com
- www.bft-usa.com



tuned to you

BFT Americas, Inc.

6100 Broken Sound Parkway N.W.,
Suite 14
Boca Raton, FL, 33487

VIRGO

DIMENSIONS

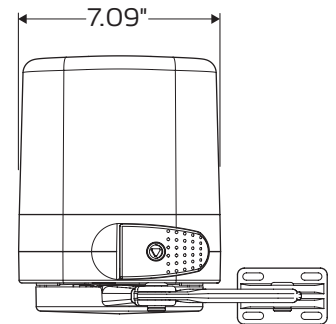
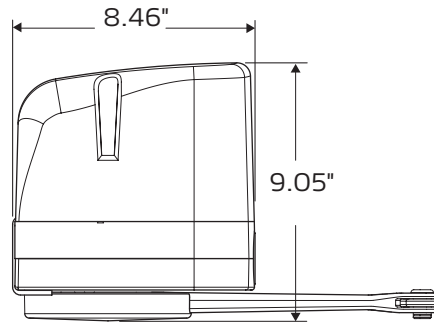

ACCESSORIES



P125008 - VIRGO BAT
24 Vdc battery backup system for VIRGO, it includes a charger board that activates batteries when power is off and charges the batteries when power is on.



D121017 - ECB SX
Left-hand horizontal electric lock. Also available in right-hand and vertical versions.



D111761 - ME BT
12/24 Vac electric lock interface for ECB locks with BT operators.



N574005 - SIBOX
Empty safe for external release and control push-button panel.

Dimensions: 7"x5"x3' 1/2."



N733036 - MOX
External release mechanism for Sibox.



P121024 - Q-BOX
Digital keypad with 10 channels and 100 combinations. Backlit



KED113731H - ECOSOL KIT
Includes Ecosol Interface, solar panel and 15' solar of panel cable, connection harness for easy installation, for running BFT control panels off 24V solar power. Includes two 12V 7.2Ah batteries and circuit board for management of commands to control panel and battery charge management, with built-in Rolling Code 433.92 MHz receiver with 63 stored positions.



D111904 Mitto 2 Transmitter:
12V Two channel 433Mhz rolling code remote control

- T: US. 1877 995 8155
- info.bft@bft-usa.com
- www.bft-usa.com



tuned to you

BFT Americas, Inc.
6100 Broken Sound Parkway N.W.,
Suite 14
Boca Raton, FL, 33487