

- I** AUTOMAZIONI A BRACCIO PER CANCELLI A BATTENTE
- GB** ARM AUTOMATIONS FOR SWING GATES
- F** AUTOMATIONS A BRAS POUR PORTAILS BATTANTS
- D** ARM AUTOMATIONEN FUER FLUGELGITTERTIRE
- E** AUTOMATIZACIONES A BRAZO PARA PORTONES CON BATIENTE
- P** AUTOMATIZAÇÕES DE BRAÇO PARA PORTÕES DE BATENTE

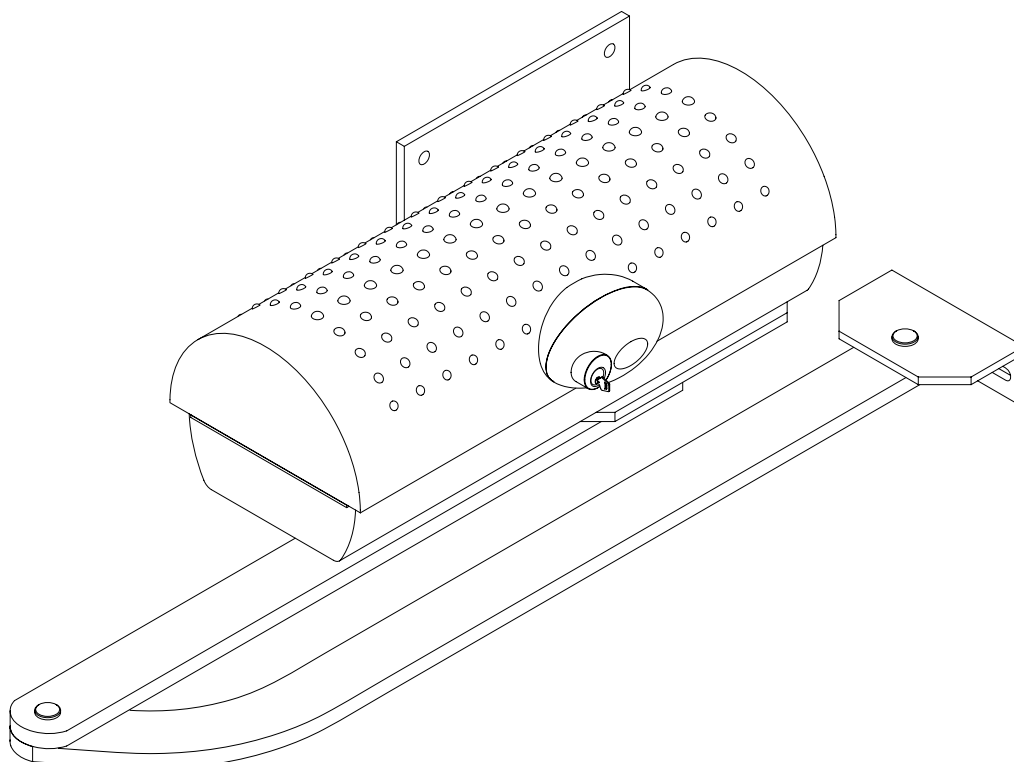

IGEA-BT



ISTRUZIONI D'USO E DI INSTALLAZIONE
INSTALLATION AND USER'S MANUAL
INSTRUCTIONS D'UTILISATION ET D'INSTALLATION
INSTALLATIONS-UND GEBRAUCHSANLEITUNG
INSTRUCCIONES DE USO Y DE INSTALACION
INSTRUÇÕES DE USO E DE INSTALAÇÃO



AZIENDA CON SISTEMA DI GESTIONE
INTEGRATO CERTIFICATO DA DNV
= UNI EN ISO 9001:2000 =
UNI EN ISO 14001:2004

Via Lago di Vico, 44
 36015 Schio (VI)
 Tel.naz. 0445 696511
 Tel.int. +39 0445 696533
 Fax 0445 696522
 Internet: www.bft.it
 E-mail: sales@bft.it

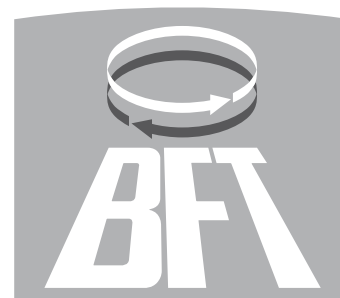

Thank you for buying this product. Our company is sure that you will be more than satisfied with the product's performance. Carefully read the "WARNINGS" pamphlet and the "INSTRUCTION BOOKLET" which are supplied together with this product, since they provide important information regarding the safety, installation, use and maintenance of the product. This product complies with recognised technical standards and safety regulations. We declare that this product is in conformity with the following European Directives: 73/23/EEC, 89/336/EEC, 98/37/EEC and subsequent amendments.

1) GENERAL OUTLINE

This Low-voltage controller (24V) is suitable for residential use and has been designed for swing gates with particularly large gate posts. The drive arm, built with a special anti-shearing shape, allows the leaves to be moved when the controller is considerably out of place with respect to the fulcrum of the leaves.

The non-reversible electro-mechanical gearmotor maintains the stop during closing and opening.

The release knob with personalised key, fitted outside each operator, makes manual manoeuvre extremely easy.

WARNING! The installation, the maintenance and the repair should be done by responsible and qualified persons with an updated knowledge of the current safety standards. It's strictly forbidden to service the automation when the power is on.

ATTENTION! The IGEA-BT model controller is not equipped with mechanical torque adjustment. It is compulsory to use a control panel of the same manufacturer, in compliance with the basic safety requirements of directives 73/23/CEE, 89/336/CEE, 89/37/CEE equipped with appropriate electric adjustment of the torque.

2) EMERGENCY MANOEUVRE (Fig. 1)

In the case of power failure or operation malfunctions, manual emergency manoeuvre can be carried out by turning the external release knob with personalised key.

First turn the key clockwise, then rotate the release knob to free the gate.

The knob is to be rotated anticlockwise in the case of a left-hand leaf, clockwise in the case of a right-hand leaf.

Keep the knob in its release position by turning the key further. Push the leaf slowly to open or close the gate.

To reactivate motor-driven operation, free the knob from its release position and bring it back to its initial position for normal operation.

WARNINGS

Correct controller operation is only ensured when the data contained in the present manual are observed. The company is not to be held responsible for any damage resulting from failure to observe the installation standards and the instructions contained in the present manual.

The descriptions and illustrations contained in the present manual are not binding. The Company reserves the right to make any alterations deemed appropriate for the technical, manufacturing and commercial improvement of the product, while leaving the essential product features unchanged, at any time and without undertaking to update the present publication.

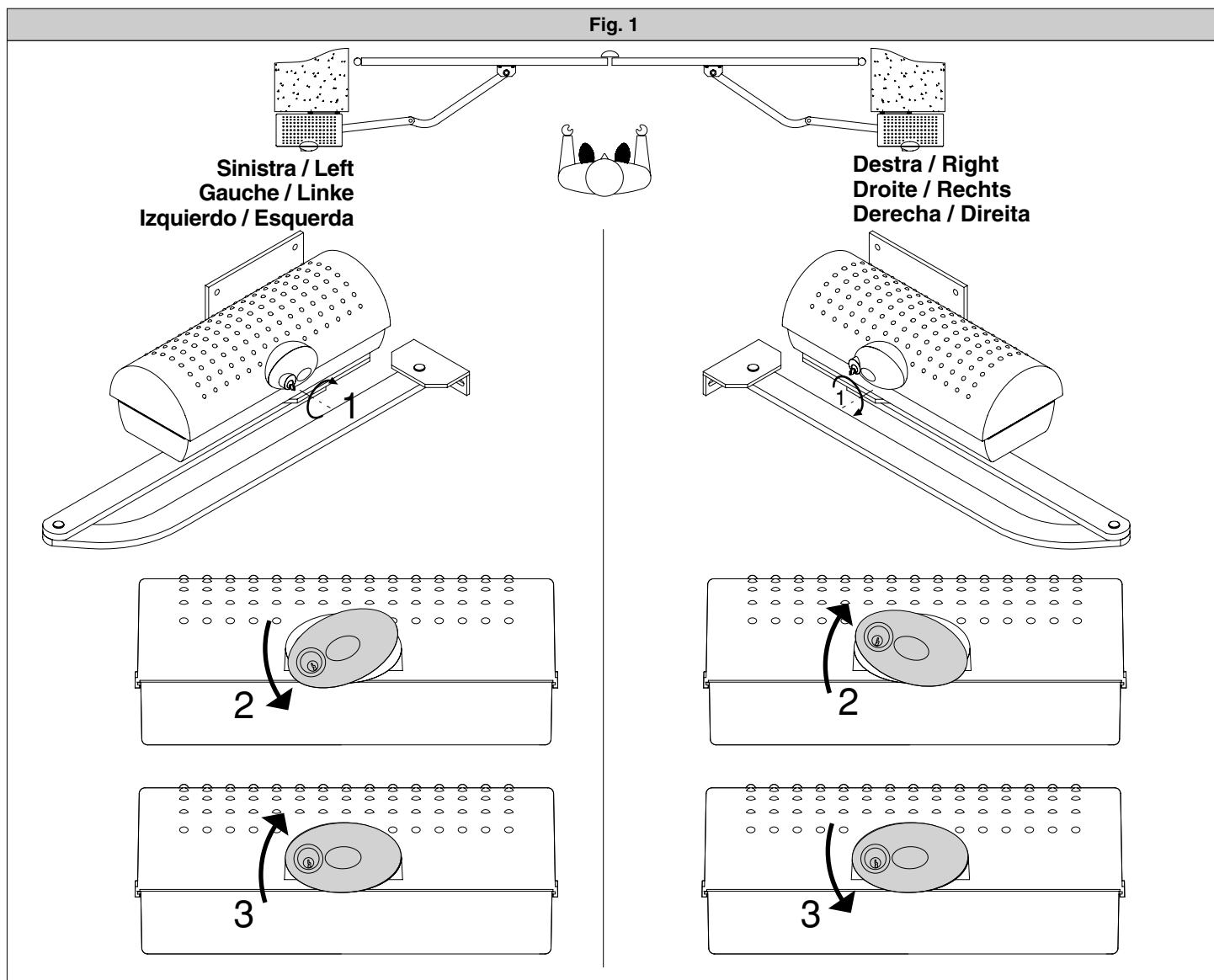

Thank you for buying this product. Our company is sure that you will be more than satisfied with the product's performance.

Carefully read the "WARNINGS" pamphlet and the "INSTRUCTION BOOKLET" which are supplied together with this product, since they provide important information regarding the safety, installation, use and maintenance of the product. This product complies with recognised technical standards and safety regulations. We declare that this product is in conformity with the following European Directives: 73/23/EEC, 89/336/EEC, 98/37/EEC and subsequent amendments.

1) GENERAL SAFETY

WARNING! An incorrect installation or improper use of the product can cause damage to persons, animals or things.

- The "Warnings" leaflet and "Instruction booklet" supplied with this product should be read carefully as they provide important information about safety, installation, use and maintenance.
- Scrap packing materials (plastic, cardboard, polystyrene etc) according to the provisions set out by current standards. Keep nylon or polystyrene bags out of children's reach.
- Keep the instructions together with the technical brochure for future reference.
- This product was exclusively designed and manufactured for the use specified in the present documentation. Any other use not specified in this documentation could damage the product and be dangerous.
- The Company declines all responsibility for any consequences resulting from improper use of the product, or use which is different from that expected and specified in the present documentation.
- Do not install the product in explosive atmosphere.
- The construction components of this product must comply with the following European Directives: 89/336/CEE, 73/23/EEC, 98/37/EEC and subsequent amendments. As for all non-EEC countries, the above-mentioned standards as well as the current national standards should be respected in order to achieve a good safety level.
- The Company declines all responsibility for any consequences resulting from failure to observe Good Technical Practice when constructing closing structures (door, gates etc.), as well as from any deformation which might occur during use.
- The installation must comply with the provisions set out by the following European Directives: 89/336/CEE, 73/23/EEC, 98/37/EEC and subsequent amendments.
- Disconnect the electrical power supply before carrying out any work on the installation. Also disconnect any buffer batteries, if fitted.
- Fit an omnipolar or magnetothermal switch on the mains power supply, having a contact opening distance equal to or greater than 3,5 mm.
- Check that a differential switch with a 0.03A threshold is fitted just before the power supply mains.
- Check that earthing is carried out correctly: connect all metal parts for closure (doors, gates etc.) and all system components provided with an earth terminal.
- Fit all the safety devices (photocells, electric edges etc.) which are needed to protect the area from any danger caused by squashing, conveying and shearing, according to and in compliance with the applicable directives and technical standards.
- Position at least one luminous signal indication device (blinker) where it can be easily seen, and fix a Warning sign to the structure.
- The Company declines all responsibility with respect to the automation safety and correct operation when other manufacturers' components are used.
- Only use original parts for any maintenance or repair operation.
- Do not modify the automation components, unless explicitly authorised by the company.
- Instruct the product user about the control systems provided and the manual opening operation in case of emergency.
- Do not allow persons or children to remain in the automation operation area.
- Keep radio control or other control devices out of children's reach, in order to avoid unintentional automation activation.
- The user must avoid any attempt to carry out work or repair on the automation system, and always request the assistance of qualified personnel.
- Anything which is not expressly provided for in the present instructions, is not allowed.

2) GENERAL OUTLINE

This Low-voltage controller (24V) is suitable for residential use and has been designed for swing gates with particularly large gate posts. The drive arm, built with a special anti-shearing shape, allows the leaves to be moved when the controller is considerably out of place with respect to the fulcrum of the leaves. The non-reversible electro-mechanical gearmotor maintains the stop during closing and opening.

The release knob with personalised key, fitted outside each operator, makes manual manoeuvre extremely easy.

WARNING! The installation, the maintenance and the repair should be done by responsible and qualified persons with an updated knowledge of the current safety standards. It's strictly forbidden to service the automation when the power is on.

ATTENTION! The IGEA-BT model controller is not equipped with mechanical torque adjustment. It is compulsory to use a control panel of the same manufacturer, in compliance with the basic safety requirements of directives 73/23/CEE, 89/336/CEE, 89/37/CEE equipped with appropriate electric adjustment of the torque.

Installation must be carried out using the safety devices and controls prescribed by the EN 12978 Standard.

3) TECHNICAL SPECIFICATIONS

Motor:	24V---1500 min ⁻¹
Power:	40W
Insulation class:	F
Lubrication:	Permanent grease
Reduction ratio:	1 : 812
Output shaft revolutions:	1.8 min ⁻¹ MAX
90° opening time:	15s
Torque supplied:	300 Nm
Weight and max leaf length:	2000N (~200kg) for 2.5m leaf length 2500N (~250kg) for 2m leaf length
Impact reaction:	Integrated torque limiter on LIBRA control panel
Motion drive:	Lever arm
Stop:	Incorporated electric limit switches
Manual manoeuvre:	Release knob with personalised key
Number of manoeuvres in 24h:	100
Environmental conditions:	-15 to +60°C
Degree of protection:	IP 44
Operator weight:	160N (~16kg)
Dimensions:	See fig. 1
Observe the safety distances as prescribed by the Standard in force.	

4) OPERATOR INSTALLATION

WARNING! Refer to Fig.A for CORRECT installation.

4.1) Preliminary checks

Check that:

- The gate structure is sufficiently sturdy and rigid. The fixing position must be worked out according to the leaf structure. In any case, the manoeuvring arm must push against a reinforced leaf point (fig. 2).
- The leaves can be moved manually along their entire stroke. If the gate has not been installed recently, check the wear condition of all its components. Repair or replace defective and worn parts. Operator reliability and safety are directly affected by the condition of the gate structure.

4.2) Fitting of the manual release knob

- With reference to fig. 9, position release knob "A" on flange "B" prefitted on the cover.
 - Insert adapting ring "C" in the bush with release tooth "D".
WARNING: Depending on the operator installation position (right or left side), insert ring "C" and position bush "D" as shown in fig. 9.
 - Insert space washer "E" and then shimmying thrust bearing "F" into bush "D" on the release tooth side.
 - Secure everything, using appropriate self-tapping screw "G" inside the operator cover, checking the correct positioning of ring "C" and bush "D".
 - Close the operator cover, using the appropriate screws supplied.
WARNING: The release tooth on bush "D" must be inserted in the release lever as shown in fig. 9b. Otherwise, the emergency manoeuvre cannot be carried out.
- Insertion is made easy by turning knob "A" to the side opposite to that for manual release (clockwise in the case of a left-hand leaf, anticlockwise in the case of a right-hand leaf) and locking it in such position by means of the appropriate key.
- Check that bush "D" is placed horizontally (fig. 9b) and close the cover by positioning its front side (the one with the release knob) as indicated in fig. 9c.
- Before connecting the operator to the power supply, manually check that the release knob operates correctly.

5) FIXING OF SUPPORTING PLATE (Fig.2)

The controller is supplied complete with anchoring bracket and lever arm. Once the reinforcement point of the leaf has been identified with the gate closed, draw an imaginary horizontal line from the centre of the reinforcement point to the gate post (fig.2). Position the anchoring bracket according to the values given in fig. 2 for openings of up to 90° or in fig.3 for openings greater than 90° up to a maximum of 125°.

The bracket fixing position must be flat and parallel to the leaf. Use screws or expansion bolts which are suited to the type of gate post. If the surface

of the gate post is not regular, use expansion bolts with studs so that the parallel plate of the leaf can be adjusted (fig.4).

- Fasten the gearmotor to the gate post using the 4 screws, pointing the gearmotor to the left or the right (fig.5).
- Assemble the lever arm as shown in fig.6.
DX= assembly on the right leaf
SX= assembly on the left leaf
Choose the most suitable position of 'F' bracket for the fastening to the leaf.
- Insert the square of the first lever in the output shaft of the gearmotor and fasten it (fig.7).
- Release the operator by turning the release knob to allow easy movement of the arm (see paragraph on "EMERGENCY MANOEUVRE").
- The correct position for the controller arm is shown in fig.8.
The leaf fixing point can be identified by positioning the arm so that it is in accordance with the distance shown in fig.8.
- Fix the angular towing bar "F" to the leaf by welding or using screws.
- With the controller released, check the correct movement of the arm.
- Repeat the same operation for the other leaf, if installed.

6) ELECTRICAL INSTALLATION SET-UP

Arrange the electrical installation as shown in fig.10.

The power supply connections must be kept separate from the auxiliary connections (photocells, sensitive edge, etc.). Fig.10 shows the cross-section and the number of connections.

WARNING! For connection to the mains, use a multipolar cable with a minimum of 4x1.5mm² cross section and complying with the previously mentioned regulations. For example, if the cable is outside (in the open), it has to be at least equal to H07RN-F, but if it is on the inside (or outside but placed in a plastic cable channel) it has to be or at least equal to H05VV-F with section 4x1.5mm².

In fig.11 you will find the junction-box of the operator and the position of the cable holder which should be fixed with an adequate tightening of the bolt. In case the motor tours in the opposite side, you should invert the running buckle "M" of the operator. Refer to the relevant instruction manual for connection of the control panel. Inside the operator the cable must be kept far from those parts which can be hot.

7) LIMIT-SWITCH SETTING

- Position the limit-switch reference cams "R-FC1" and "R-FC2" as shown in fig. 12, without tightening the fixing screws.
- Identify the opening and closing limit switches (FC1 and FC2) keeping in mind that:
In the left-hand operator (fig. 13):
FC1 corresponds to the **OPENING limit switch**
FC2 corresponds to the **CLOSING limit switch**
In the right-hand operator (fig. 14):
FC1 corresponds to the **CLOSING limit switch**
FC2 corresponds to the **OPENING limit switch**
- When the gate is fully closed or opened, rotate the corresponding cam until you perceive the click of the limit microswitch concerned, and lock it in position by tightening the appropriate screws as shown in fig. 12.
- Check that the limit switches intervene correctly, initiating a few complete motor-driven opening and closing cycles.
- Fit the cover on the operator.
- If the control panel is provided with operation-time setting, this must be set to a value slightly greater than that needed for limit-switch intervention.
- Control the operator through the control board Libra.

8) ADJUSTMENT OF LEAF PHASE DISPLACEMENT

In case of gates with two leaves, the control panel should include a delay setting function on closing of the second leaf to guarantee a correct closing manoeuvre. For the wiring of the motor which should close with a slight delay, refer to the instructions for the control panel installed.

9) MOTOR TORQUE ADJUSTMENT

WARNING: Check that the impact force value measured at the points established by the EN 12445 standard is lower than that specified in the EN 12453 standard.

The adjustment of the motor torque (anti-squashing) is performed on the control panel. See control unit instruction manual.

The adjustment should be set for the minimum force required to carry out the opening and closing strokes completely observing, however, the limits of the relevant standards in force.

CAUTION! Excessive torque adjustment may jeopardise the anti-squash safety function. On the other hand insufficient torque adjustment may not guarantee correct opening or closing strokes.

10) EMERGENCY MANOEUVRE (Fig. 15)

In the case of power failure or operation malfunctions, manual emergency manoeuvre can be carried out by turning the external release knob with personalised key.

First turn the key clockwise, then rotate the release knob to free the gate.

The knob is to be rotated anticlockwise in the case of a left-hand leaf, clockwise in the case of a right-hand leaf.

Keep the knob in its release position by turning the key further. Push the leaf slowly to open or close the gate.

To reactivate motor-driven operation, free the knob from its release position and bring it back to its initial position for normal operation.

11) AUTOMATION CHECK

Before allowing the automation to be used normally, carry out the following procedure very carefully:

- Check the correct functioning of all safety devices (limit microswitches, photocells, sensitive edges etc.).
- Check that the thrust (anti-squash) force of the leaf is within the limits set by current regulations.
- Check the manual opening command.
- Check the opening and closing operations with the control devices in use.
- Check the standard and customised electronic functioning logic.

12) AUTOMATION OPERATION

Since the automation can be remote-controlled by means of a remote control device or a start button, and so out of sight, the good working order of all the safety devices should be checked regularly. In the event of any anomalous functioning of the safety devices, consult a specialised technician immediately. Keep children at a safe distance from the automation operation area.

13) CONTROL

The automation is used for the power-operated opening and closing of the gate. The control can be of a number of types (manual, remote-controlled, magnetic badge access control, etc.) depending on requirements and the characteristics of the installation. See the specific instructions for the various control systems. Users of the automation must be instructed about its control and operation.

14) MAINTENANCE

Disconnect the power supply when carrying out any maintenance operations.

- Lubricate the **IGEA-BT**s of the manoeuvring arm regularly.
- Clean the lenses of the photocells every so often.
- Have a specialised technician (installer) check the adjustment of the electric clutch.
- In the event of any anomalous functioning which cannot be resolved, disconnect the power supply and contact a specialised technician (installer). Whilst the automation is out of order, activate the manual release to allow manual opening and closing.

15) SCRAPPING

WARNING! This operation should only be carried out by qualified personnel.

Materials must be disposed of in conformity with the current regulations. In case of scrapping, the automation devices do not entail any particular risks or danger. In case of materials to be recycled, these should be sorted out by type (electrical components, copper, aluminium, plastic etc.).

16) DISMANTLING

WARNING! This operation should only be carried out by qualified personnel.

When the automation system is disassembled to be reassembled on another site, proceed as follows:

- Disconnect the power supply and the entire external electrical installation.
- In the case where some of the components cannot be removed or are damaged, they must be replaced.

WARNINGS

Correct controller operation is only ensured when the data contained in the present manual are observed. The company is not to be held responsible for any damage resulting from failure to observe the installation standards and the instructions contained in the present manual.

The descriptions and illustrations contained in the present manual are not binding. The Company reserves the right to make any alterations deemed appropriate for the technical, manufacturing and commercial improvement of the product, while leaving the essential product features unchanged, at any time and without undertaking to update the present publication.

Fig. A

CORRETTO / RIGHT / JUSTE / RICHTIG / CORRECTO / JUSTO:

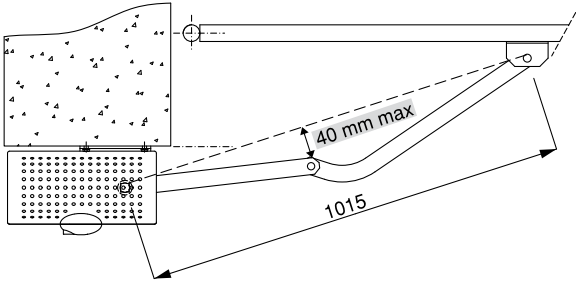

NON CORRETTO / WRONG / FAUX / FALSCH / NO CORRECTO / ERRADO:

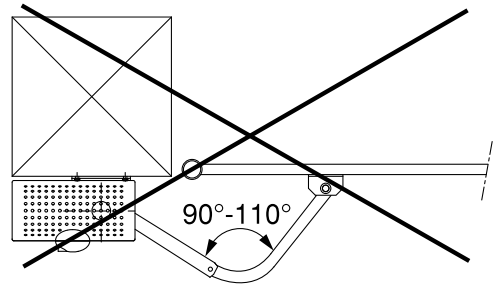

Fig. 1

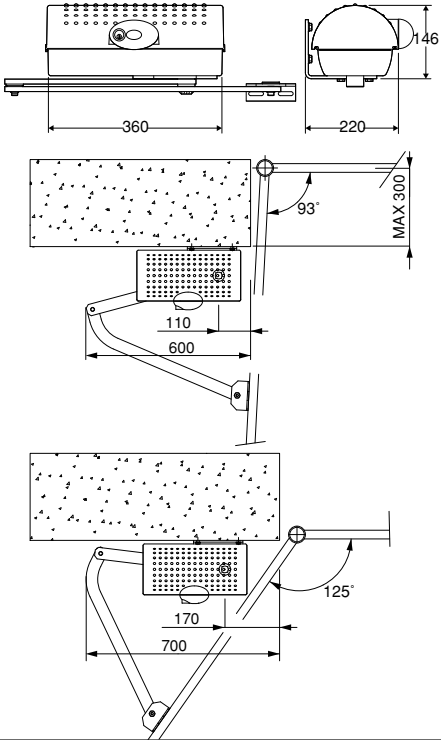

Fig. 2

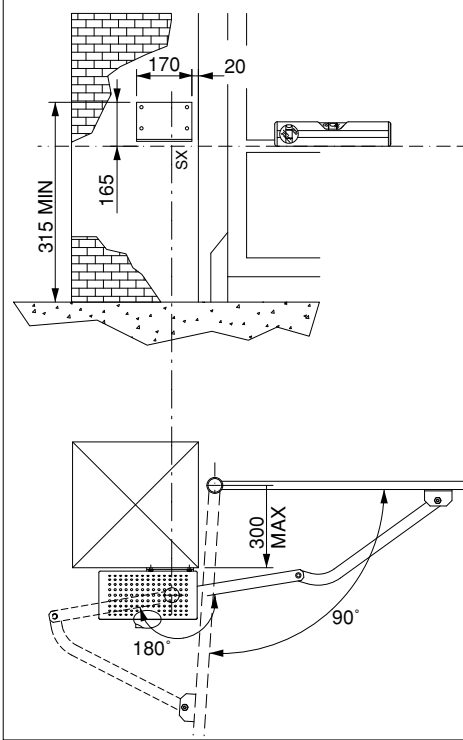

Fig. 3

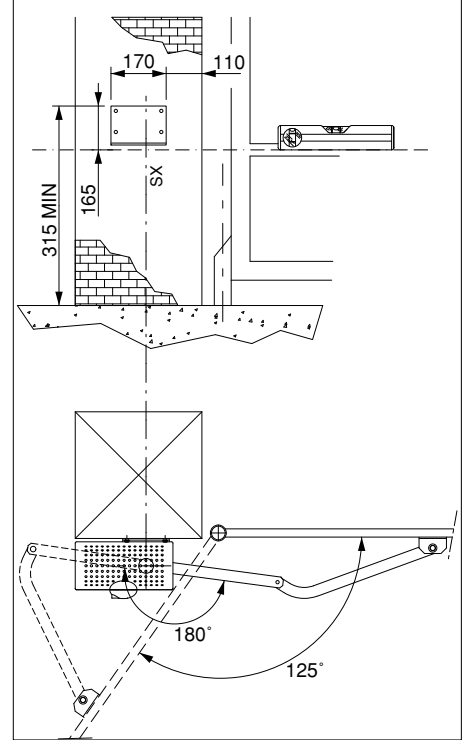

Fig. 4

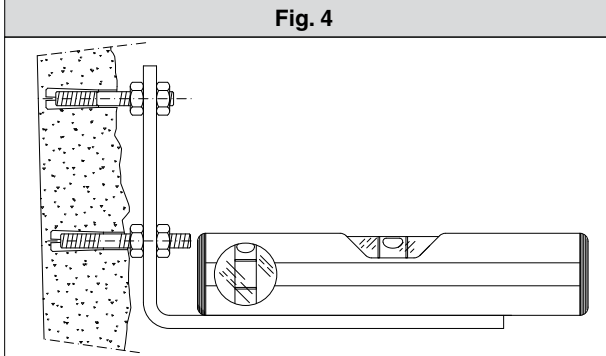

Fig. 5

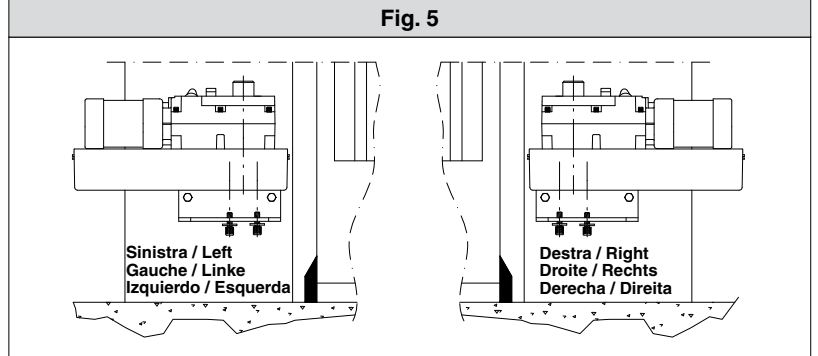

Fig. 6

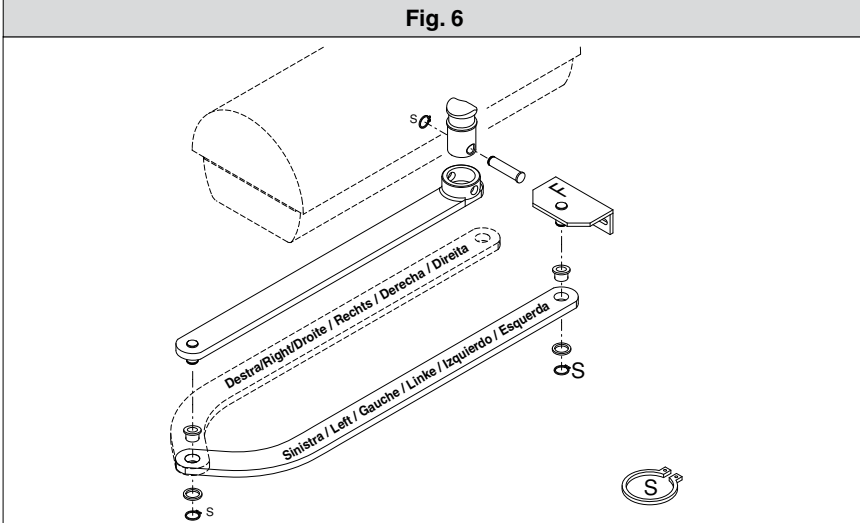

Fig. 7

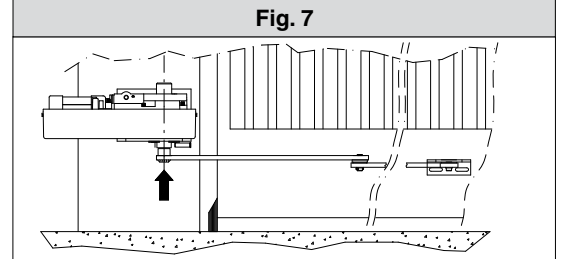

Fig. 8

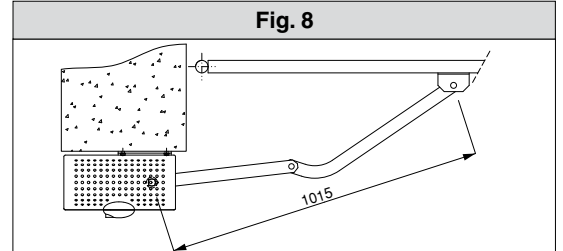
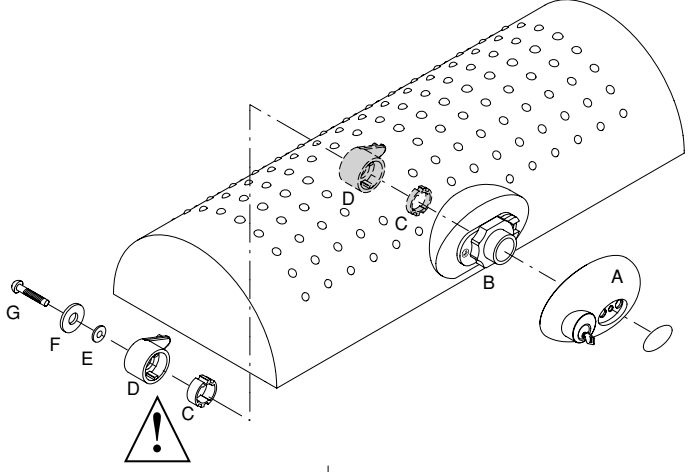
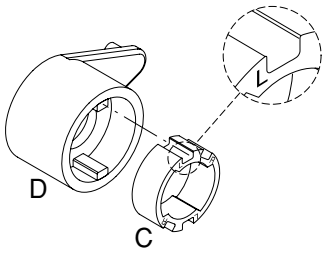

Fig. 9



Sinistra
Left
Gauche
Linke
Izquierdo
Esquerda



Destra
Right
Droite
Rechts
Derecha
Direita

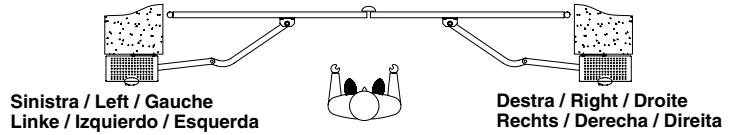
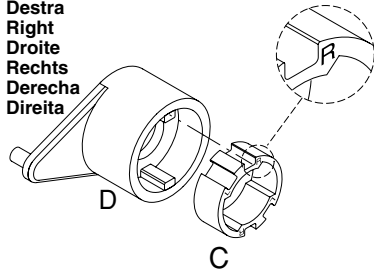

Sinistra / Left / Gauche
Linke / Izquierdo / Esquerda

Destra / Right / Droite
Rechts / Derecha / Direita

Fig. 9b

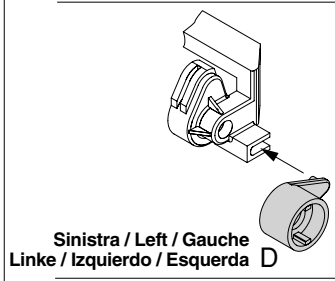
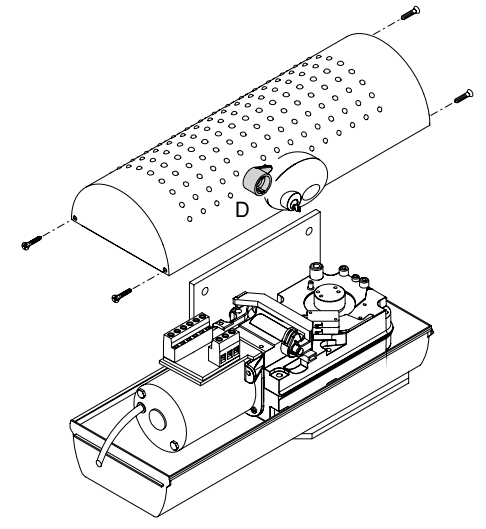

Sinistra / Left / Gauche
Linke / Izquierdo / Esquerda D

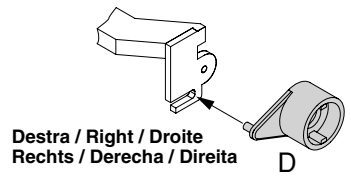

Destra / Right / Droite
Rechts / Derecha / Direita D

Fig. 9c

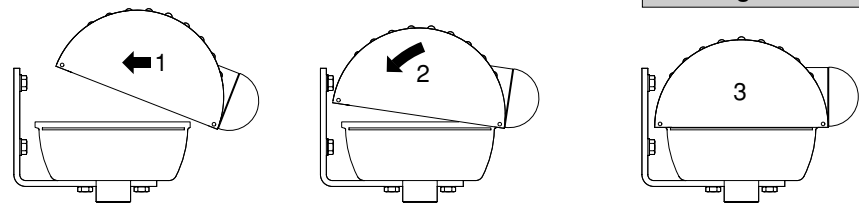

Fig. 10

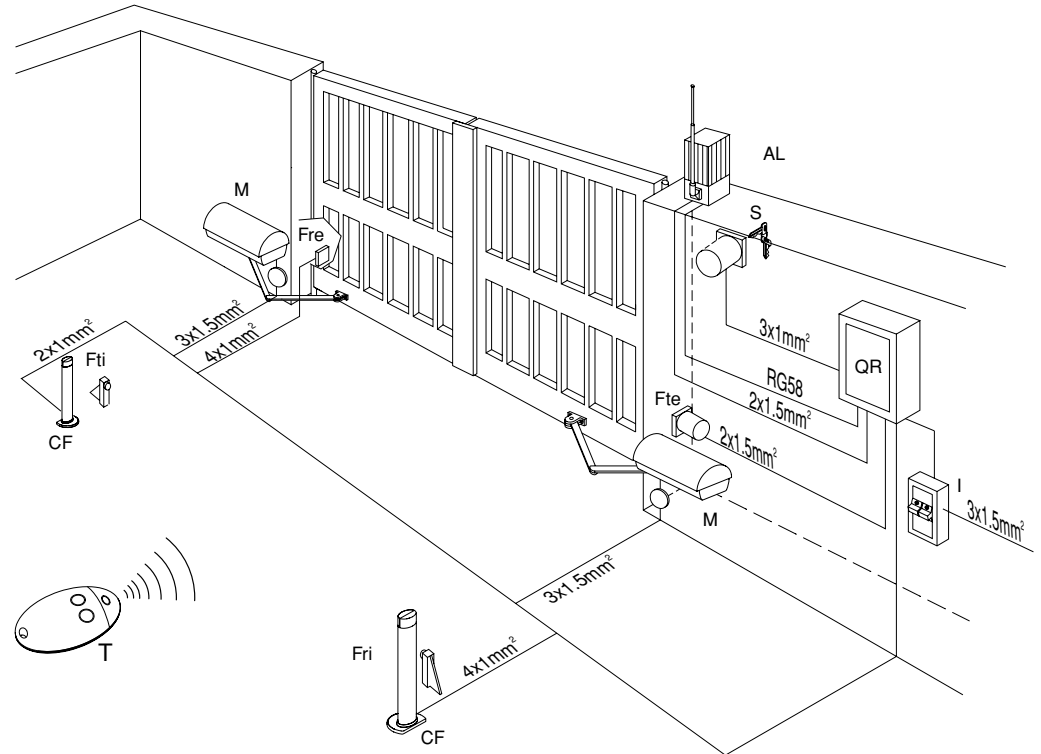

Fig. 11

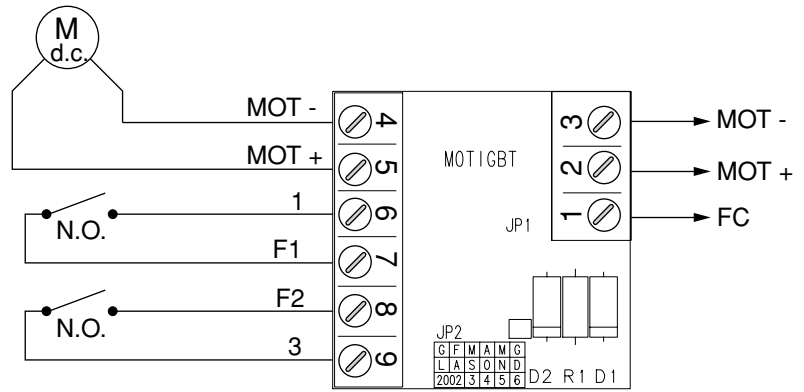
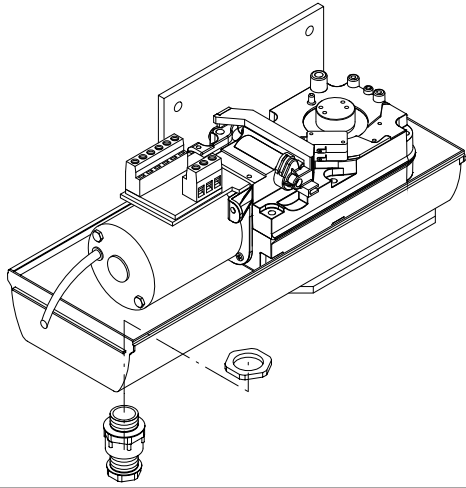

Fig. 12

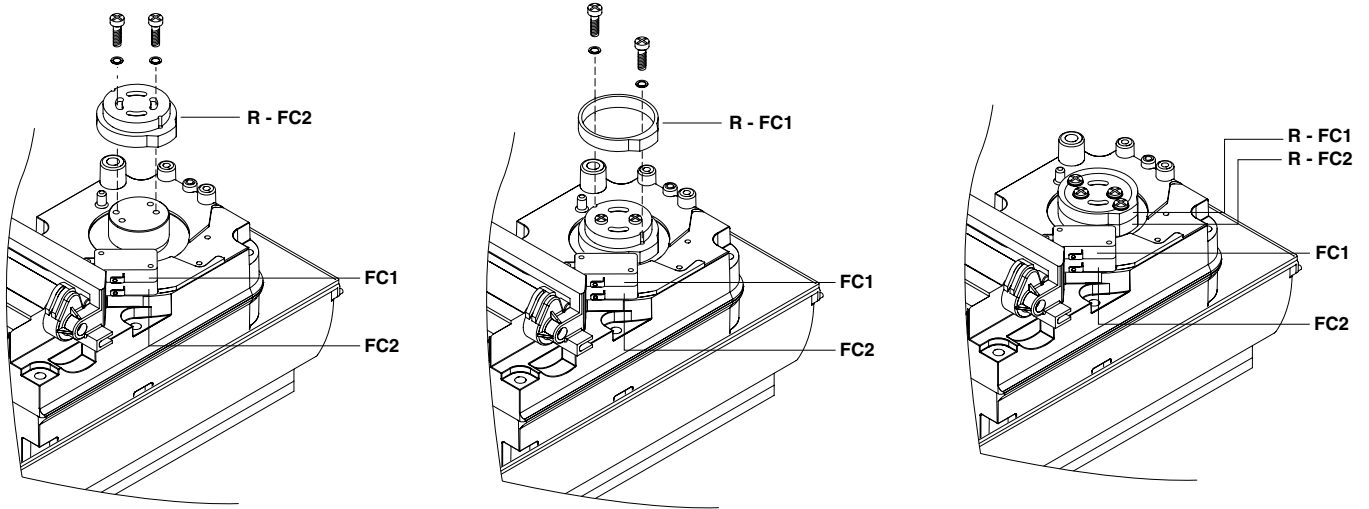

Fig. 13

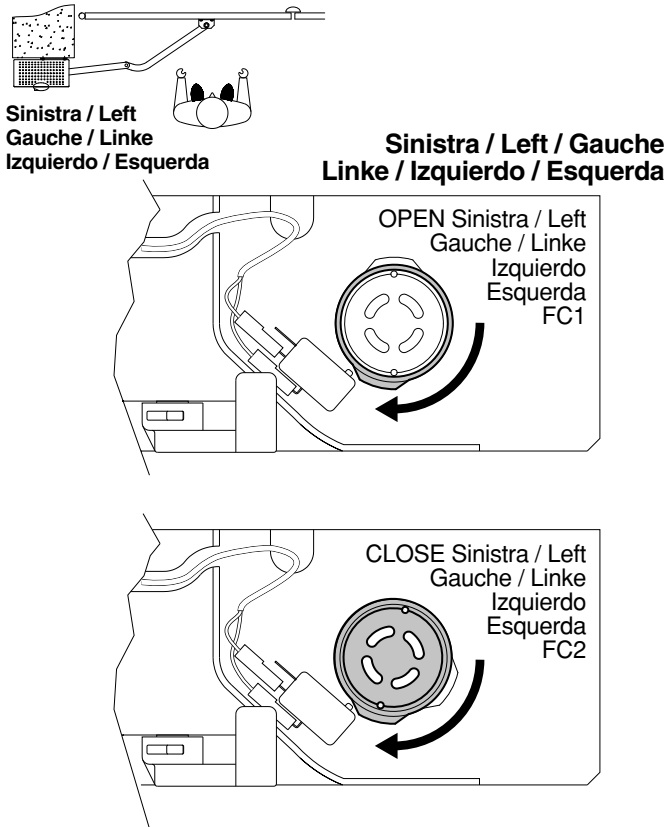

Fig. 14

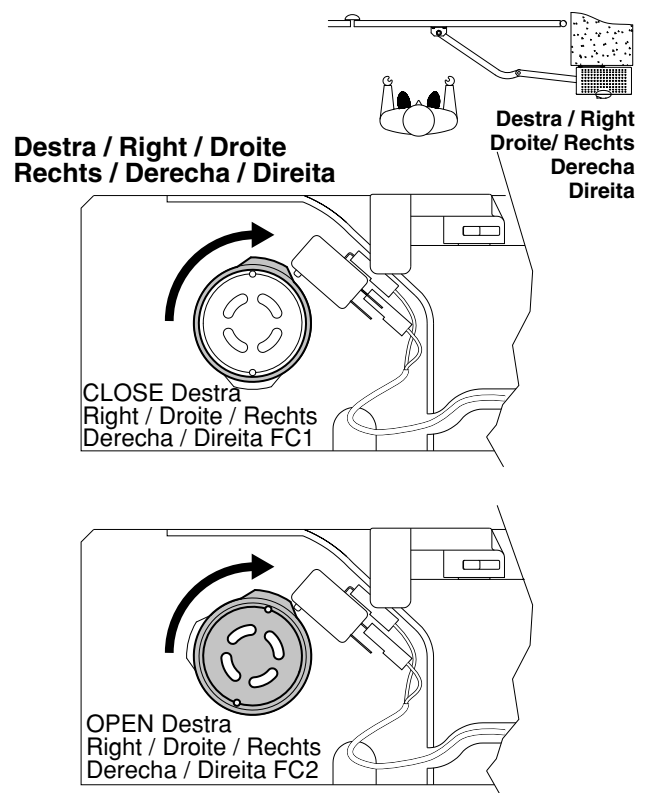

Fig. 15

**Sinistra / Left
Gauche / Linke
Izquierdo / Esquerda**

**Destra / Right
Droite / Rechts
Derecha / Direita**

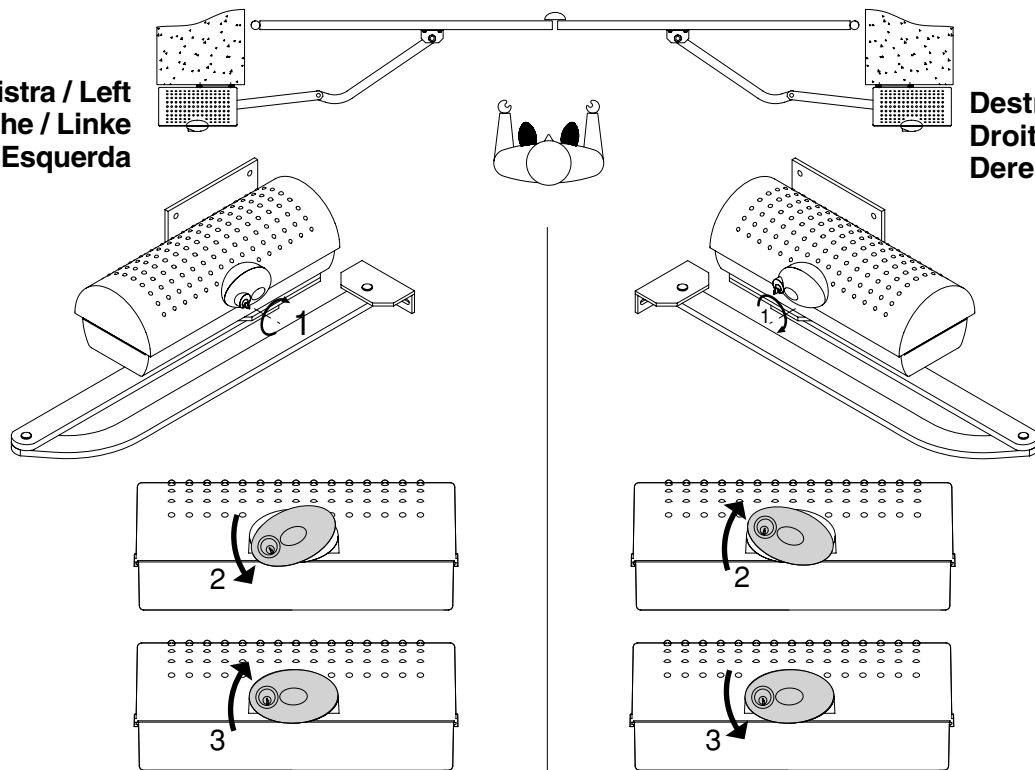
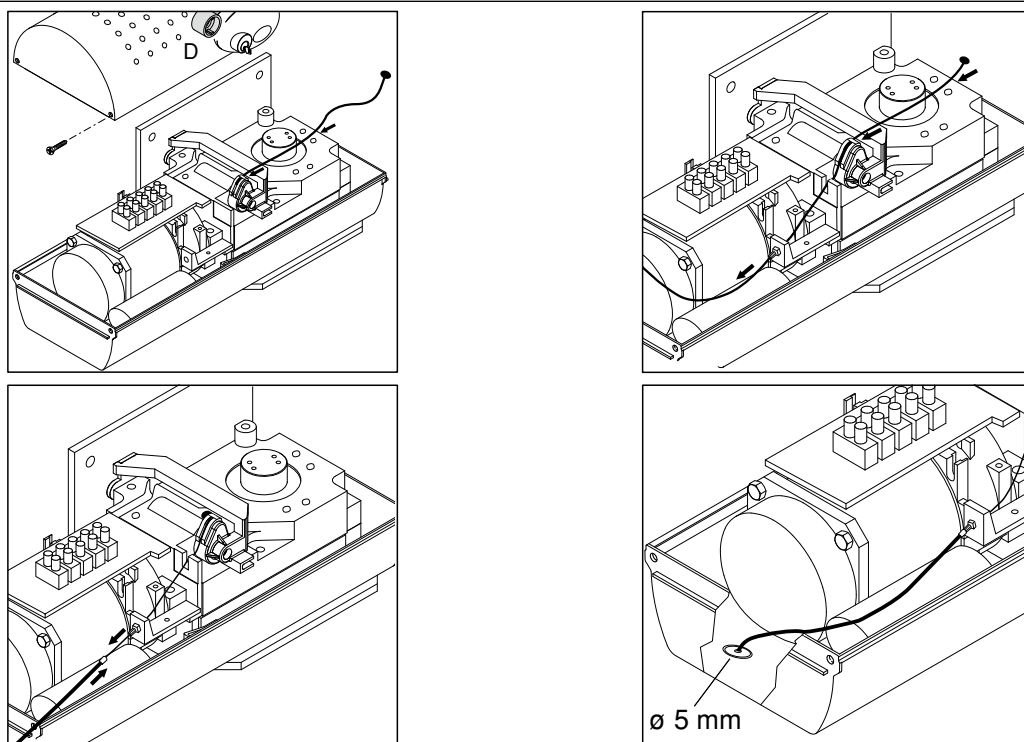

Fig. 16



BFT S.P.A.
Via Lago di Vico 44, 36015 Schio (Vi) - **Italy**
tel. +39 0445 69 65 11 / fax. +39 0445 69 65 22
www.bft.it / e-mail: info@bft.it

AUTOMATISMES BFT FRANCE
13 Bdl. E. Michelet, 69008 Lyon - **France**
tel. +33 (0)4 78 76 09 88 - fax +33 (0)4 78 76 92 23
e-mail: contacts@automatismes-bft-france.fr



BFT Torantriebssysteme GmbH
Faber-Castell-Straße 29
D - 90522 Oberasbach - **Germany**
tel. +49 (0)911 766 00 90 - fax +49 (0)911 766 00 99
e-mail: service@bft-torantriebe.de

BFT Automation UK Ltd
Unit 8E, Newby Road
Industrial Estate Hazel Grove, Stockport,
Cheshire, SK7 5DA - **UK**
tel. +44 (0) 161 4560456 - fax +44 (0) 161 4569090
e-mail: info@bftautomation.co.uk

BFT BENELUX SA
Parc Industriel 1, Rue du commerce 12
1400 Nivelles - **Belgium**
tel. +32 (0)67 55 02 00 - fax +32 (0)67 55 02 01
e-mail: info@bftbenelux.be

BFT-ADRIA d.o.o.
Obrovac 39
51218 Dražice (Rijeka)
Hrvatska - **Croatia**
tel. +385 (0)51 502 640 - fax +385 (0)51 502 644
e-mail: info@bft.hr

BFT Polska Sp. z o.o.
ul. Kołacińska 35
03-171 Warszawa - **Poland**
tel. +48 22 814 12 22 - fax +48 22 814 39 18
e-mail: biuro@bft.com.pl

BFT USA BFT U.S., Inc.
6100 Broken Sound Pkwy. N.W., Suite 14
Boca Raton, FL 33487 - **U.S.A.**
T: +1 561.995.8155 - F: +1 561.995.8160
TOLL FREE 1.877.995.8155 - info.bft@bft-usa.com

BFT GROUP ITALIBERICA DE AUTOMATISMOS S.L.
Pol. Palou Nord,
Sector F - C/Cami - Can Basa nº 6-8 08401 Granollers -
(Barcelona) - Spain
tel. +34 938 61 48 28 - fax +34 938 70 03 94
e-mail: bftbcn@bftautomatismos.com

Pl. Comendador - C/
informática, Nave 22 - 19200 Azuqueca de henares
(Guadalajara) - Spain
tel. +34 938 26 32 00 - fax +34 938 26 24 51
e-mail: administracion@bftautomatismos.com

BFT SA - COMERCIO DE AUTOMATISMOS E MATERIAL DE SEGURANÇA
Urbanizaçao da Pedrulha Lote 9 - Apartado 8123,
3020-305 COIMBRA - **PORTUGAL**
tel. +351 239 082 790 - fax +351 239 082 799
e-mail: geral@bftportugal.com