

ICARO

RANGE

Electromechanical automation for rack sliding gates up to 2,200 lbs and 75 Feet and up to 4,400 lbs with 18 teeth pinion

ICARO FAST

P925226 00001

SMART TECHNOLOGY

Incorporated two-channel rolling code radio receiver, plug-in connector for connection of a second receiver.

Control unit with self-learning and self-diagnostic functions of the parameters: brake, torque, obstruction detection.

Control unit compatible with the EElink protocol



SAFE USE

- Thanks to the obstruction sensing device, the operator reverses motion and prevents damage to people and vehicles in the event of contact.
- Incorporated control unit positioned frontally for easier accessibility.
- Control unit programming by LCD display.



TECHNICAL FEATURES

Control panel	LEO B CBB (incorporated)
Reversible/irreversible operator	irreversible
Power supply	120 V, 60 Hz single-phase
Absorbed power	1 hp (750 W)
Thermal protection	integrated
Leaf speed	7.9 ips (12 m/min)
Output rotational speed	37 rpm
Pinion pitch	4 mm (25 teeth)
Impact reaction	electronic clutch with encoder
Limit switches	electromechanical
Manual release	mechanical release with knob
Operating cycle	intensive use
Environmental conditions	from 5°F (-15°C) to 140°F (+60°C)
Degree of protection	IP24
Operator weight	56 lbs (~25 kg)
Frequency of use	very Intensive

- T: US. 1877 995 8155
- info.bft@bft-usa.com
- www.bft-usa.com



tuned to you

BFT Americas, Inc.

6100 Broken Sound Parkway N.W.,
Suite 14
Boca Raton, FL, 33487

DIMENSIONS

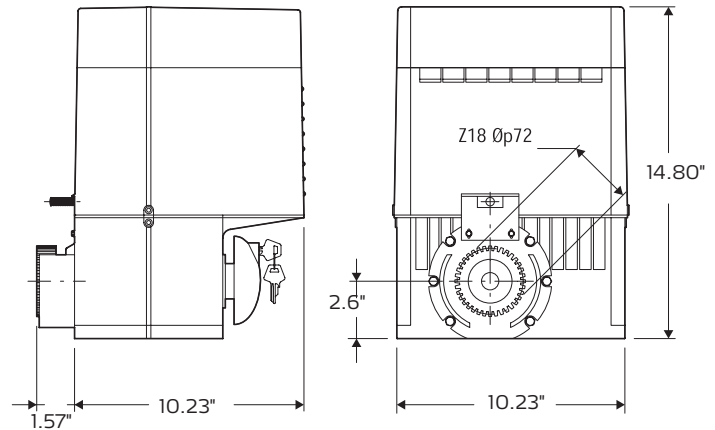

ACCESSORIES



P111376 - SCS 1
Serial connection interface for QSC D UL, RIGEL 5 and LEO B CBB. 2 SCS 1 are needed for master & slave connection.



N999158 - MSC
Personalised key release knob.

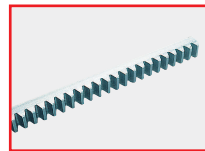

D571054 - CFZ
22x22 4mm-pitch galvanized rack. Sold in 6'6" length only.

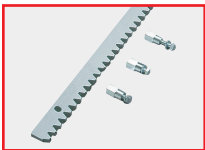

D571053 - CVZ
30x12 4mm pitch galvanised adjustable steel rack 3' 3" length.

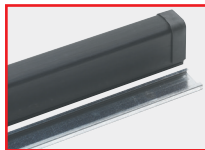

N190039 - CSP 10
Shock absorber profile, length 3' 3".

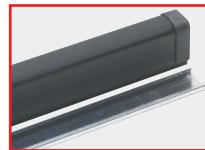

N190040 - CSP 20
Shock absorber profile, length 6' 6".



N190041 - CSP 25
Shock absorber profile, length 8' 2".



D531548 - KI
Blank spare key for release Knob



D561127 - 18 TEETH PINION
Larger pinion for increased capacity (4400Lbs - 2000Kg) Leaf Speed 5.9" /sec.

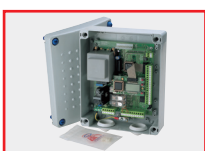

I096825 - LEO B CBB
replacement board for 120V Icaro and Icaro fast.



P121024 - Q-BOX
Digital keypad with 10 channels and 100 combinations. Backlit



D111904 Mitto 2 Transmitter:
12V Two channel 433Mhz rolling code remote control